

Arch Environmental Equipment, Inc.

ARCH V-PLOW

INSTALLATION INSTRUCTIONS

THE TOOLS AND RESOURCES REQUIRED ARE:

- | | |
|----------------------|----------------------|
| 1. CUTTING TORCH | 4. ADJUSTABLE WRENCH |
| 2. WELDING EQUIPMENT | 5. TAPE MEASURE |
| 3. CHALK | |

SHUT DOWN AND LOCKOUT CONVEYOR BEFORE PERFORMING ANY MAINTENANCE

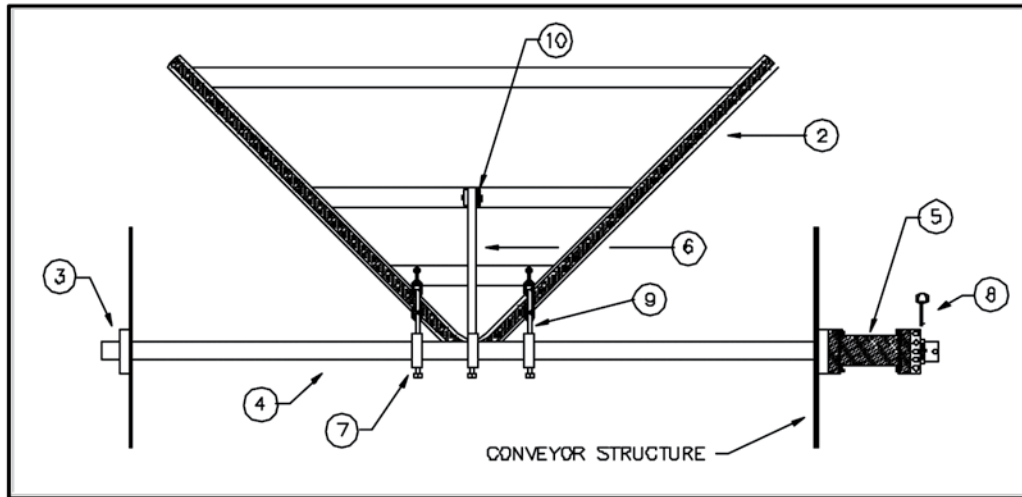

STEP 1

The Gordon V-Plow assembly should be mounted as close to the tail pulley as possible. The centerline of the tensioner pipe (item 4) should be located $9 \frac{3}{8}''$ (238.13mm) above the return side of the belt. Once the hole location is determined, a 3'' (76.2mm) diameter hole needs to be cut in the structure. (If no structure is available, you may have to fabricate the mounting structure on sight. Keep in mind, you need at least $4 \frac{3}{4}''$ (120.6mm) of area to mount this cleaner.)

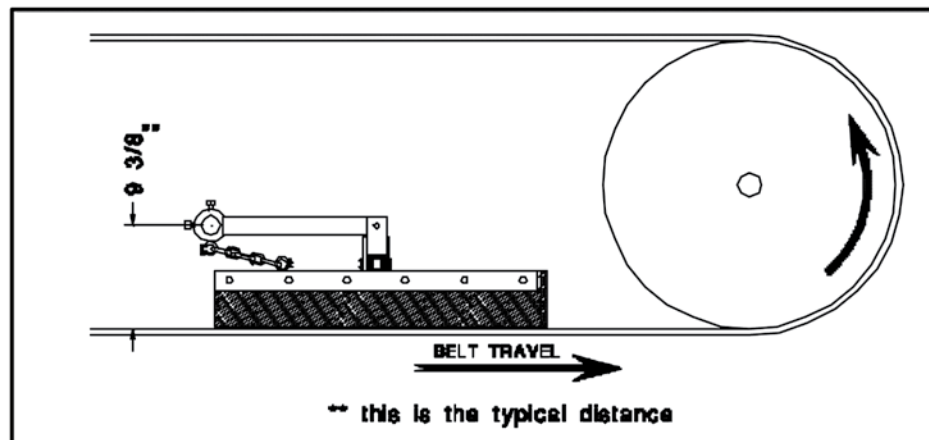

STEP 2

Once the holes have been cut, you will need to weld the tensioner (item 5) and the support hub (item 3) to opposite sides of the structure. When complete, slide the tensioner pipe (item 4) through the tensioner (item 5), then one of the retaining assembly collars (item 7). The pipe must slide through the tensioner arm (item 6) and through the other retaining assembly collar (item 7). The pipe should now slide through the support hub (item 3).

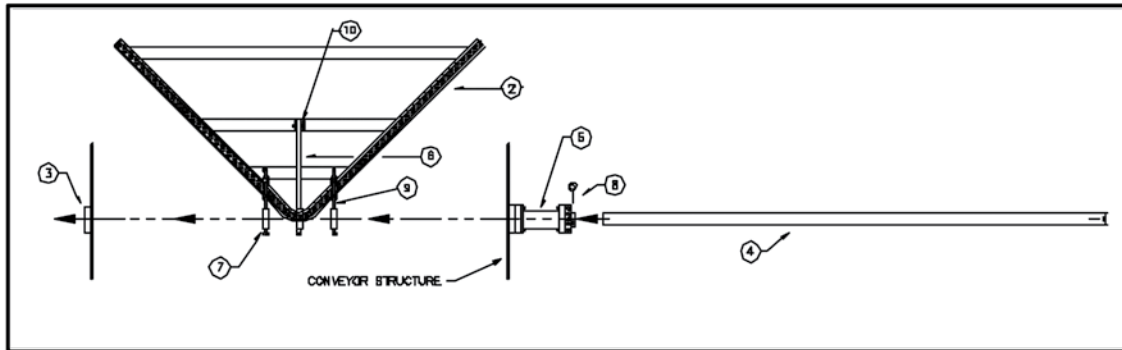

STEP 3

Now you need to tighten all the set screws against the tensioner pipe (item 4). Tighten the screws on the tensioner arm (item 6) first. Now rotate the retaining assembly collars (item 7) towards the front of the plow (to eliminate the slack in the chains) and tighten the screws.

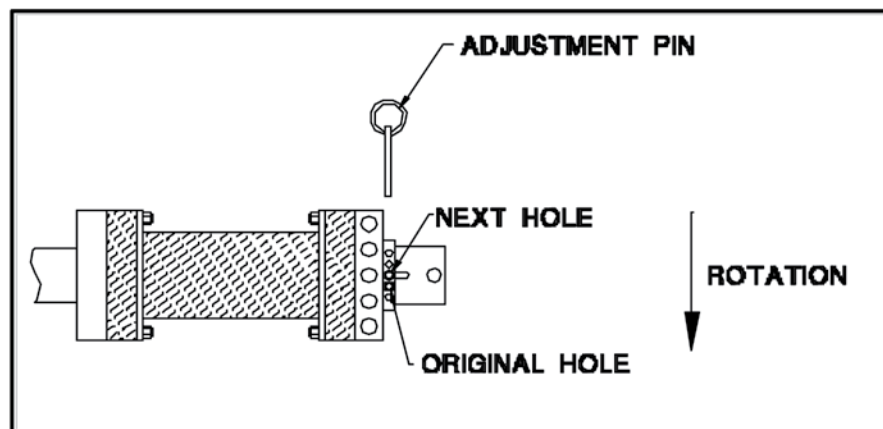

STEP 4

You must now tension the cleaner. This is done by rotating the tensioner (using the tensioning tool provided) in the opposite direction of the belt travel. Rotate the tensioner until you can see the next hole on the tensioner align with the slot in the tensioner pipe. Now place the adjustment pin through the tensioner and tensioner pipe. That's it!

