

REVISIONS		
A	SH	022502 ADDED PART NUMBERS
A	RF	110107 CHANGED LAYERS

ITEM	QTY.	DESCRIPTION	PART #
1	1	GORDON SABER BLADE	MRBG500018E000
2	1	URETHANE TENSIONER	MCRTB000200
3	1	BLADE HOLDER ASSEMBLY	MFRSC00018E00018E0000
4	1	SUPPORT / TENSIONER PIPE	MCRTPD06R00
5	1	SHEAR PIN	MCRRP0000
6	1	WELD COLLAR	MCRHS000000
	1	WRENCH NOT SHOWN	MCRW000000
8	2	PIVOT ARM	PA-Q14-BAL

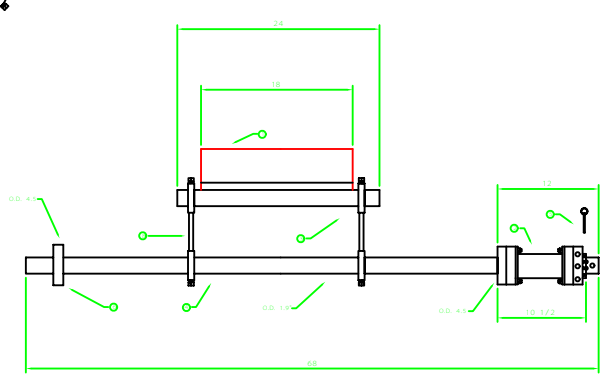
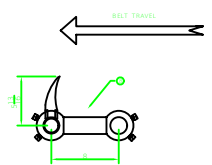

FILENAME = GSS-18  
 PLOTSCALE = 1:1

ARCH ENVIRONMENTAL EQUIP., INC.			
DATE	DRAWN	BY	
REVISION	DATE	BY	
DESCRIPTION	W.C.A.	DATE	
PROJECT	18-18	DATE	11/14
ISSUED	11/14	BY	JL

GORDON SABER  
 GSS-18-UR-TA  
 SECONDARY CLEANER

REVISIONS				ITEM
A	SH	022502	ADDED PART NUMBERS	1
B	CF	110507	CHANGED LAYERS	2
				3
				4
				5
				6
				8

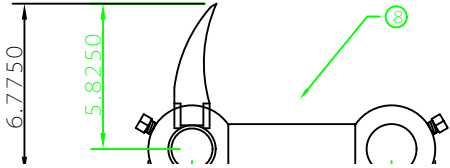

REVISIONS

A	SH	022502	ADDED PART NUMBERS
B	CF	110507	CHANGED LAYERS

ITEM	QTY.	DESCRIPTION	PART #
1	1	GORDON SABER BLADE	MRBGS00030F000
2	1	URETHANE TENSIONER	MCRTRD00200
3	1	BLADE HOLDER ASSEMBLY	MFRSC00030F00030F0000
4	1	SUPPORT / TENSIONER PIPE	MCRPTP08000
5	1	SHEAR PIN	MCRRIP000NO
6	1	WELD COLLAR	MCRHSU00000
	1	WRENCH NOT SHOWN	MCRW00000NO
8	2	PIVOT ARM	PA - 014 - 8AL

BELT TRAVEL

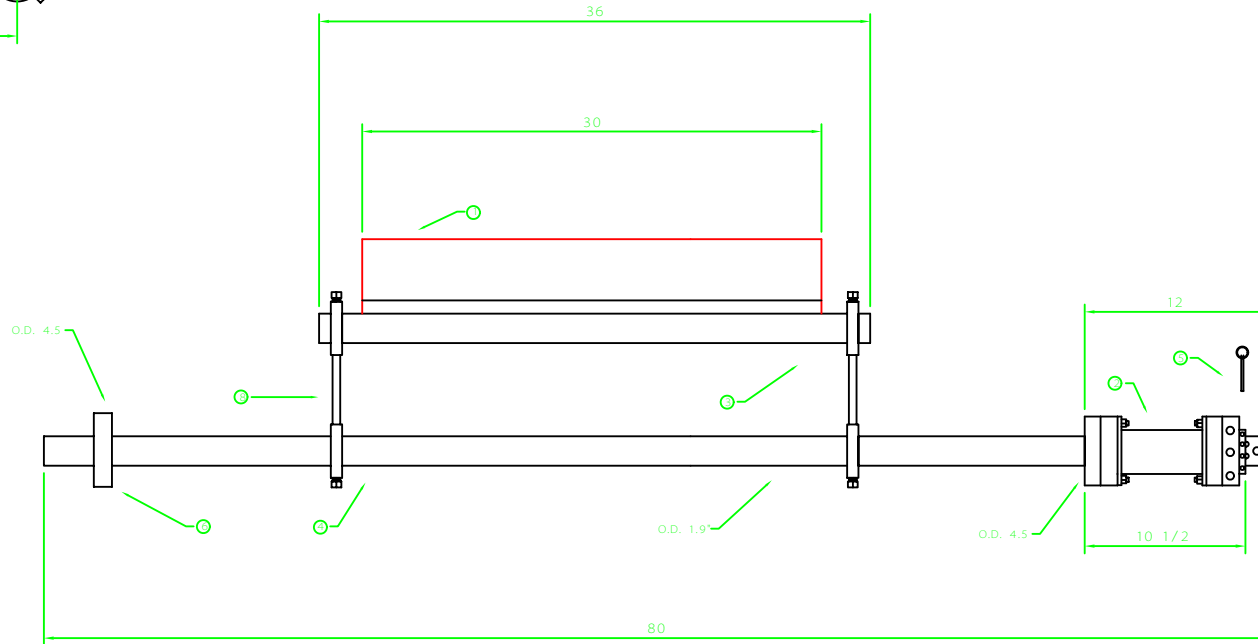
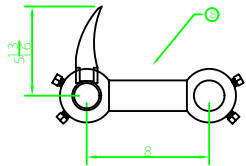

ARCH ENVIRONMENTAL EQUIP., INC.

GORDON SABER  
GSS - 30 - UR - TA  
SECONDARY CLEANER

DRAWN:	S. HOWARD	DATE
CHECKED:	G. K. W.	DATE
APPROVED:	N. F. A.	DATE
SCALE	JOB NO.	

DRAWING NO.	112092M	SHEET	OF	REV.	A
-------------	---------	-------	----	------	---

REVISIONS			
A	SH	022502	ADDED PART NUMBERS
B	CF	110507	CHANGED LAYERS

ITEM	QTY.	DESCRIPTION	PART #
1	1	GORDON SABER BLADE	MRBGS00036F000
2	1	URETHANE TENSIONER	MCRTRD00200
3	1	BLADE HOLDER ASSEMBLY	MFRSC00036F00036F0000
4	1	SUPPORT / TENSIONER PIPE	MCRPTP08600
5	1	SHEAR PIN	MCRRIP000NO
6	1	WELD COLLAR	MCRHSU00000
	1	WRENCH NOT SHOWN	MCRW00000NO
8	2	PIVOT ARM	PA-014-8AL

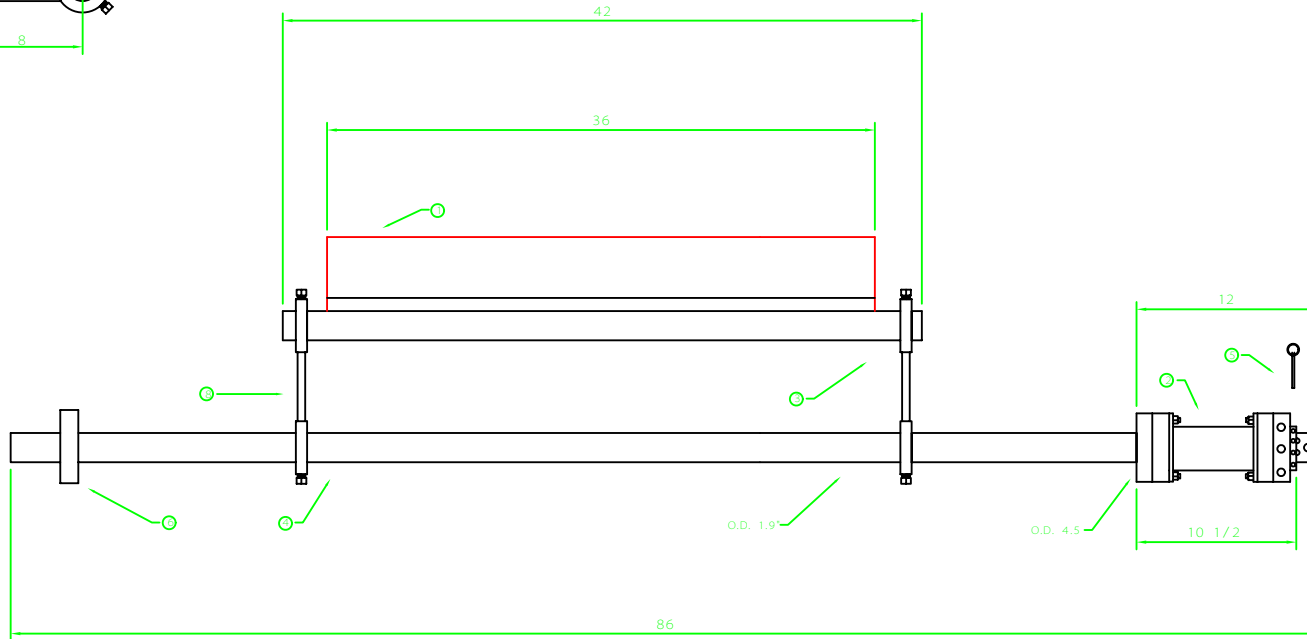
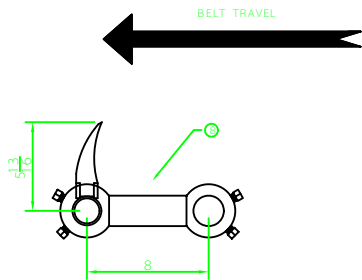

FILENAME= GSS-36  
 PLOTSCALE=1=4

DRAWN:	S. HOWARD	DATE:	
CHECKED:	G. K. W.	DATE:	
APPROVED:	N. F. A.	DATE:	
SCALE:		JOB No.:	

ARCH ENVIRONMENTAL EQUIP., INC.			
GORDON SABER GSS-36-UR-TA SECONDARY CLEANER			
DRAWING NO.:	112092M	SHEET	OF
REV.:	A		

REVISIONS

A	SH	022502	ADDED PART NUMBERS
B	CF	110507	CHANGED LAYERS

ITEM	QTY.	DESCRIPTION	PART #
1	1	GORDON SABER BLADE	MRBGS00042F000
2	1	URETHANE TENSIONER	MCRTRD00200
3	1	BLADE HOLDER ASSEMBLY	MFRSC00042F00042F0000
4	1	SUPPORT / TENSIONER PIPE	MCRPTP09200
5	1	SHEAR PIN	MCRBIP000NO
6	1	WELD COLLAR	MCRHSU00000
7	1	WRENCH NOT SHOWN	MCRW00000NO
8	2	PIVOT ARM	PA-014-8AL

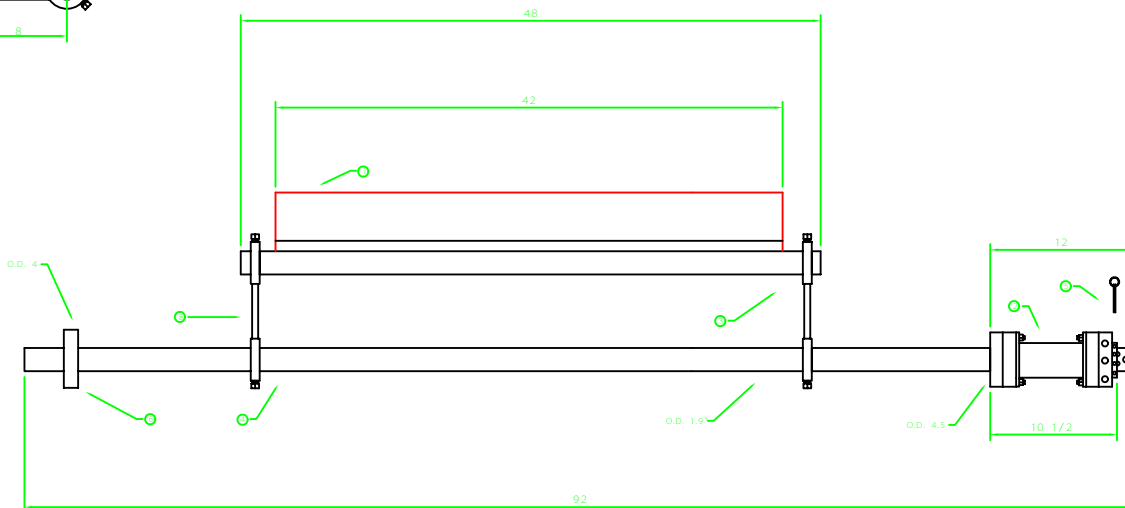
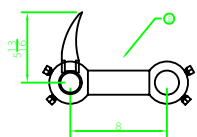

ARCH ENVIRONMENTAL EQUIP., INC.

GORDON SABER  
GSS - 42 - UR - TA  
SECONDARY CLEANER

DRAWN	S. HOWARD	DATE
CHECKED	G. K. W.	DATE
APPROVED	N. F. A.	DATE
SCALE	JOB NO.	

DRAWING NO.	112092N	SHEET	OF	REV.	A
-------------	---------	-------	----	------	---

REVISIONS

A	SH	022502	ADDED PART NUMBERS
B	CF	110507	CHANGED LAYERS

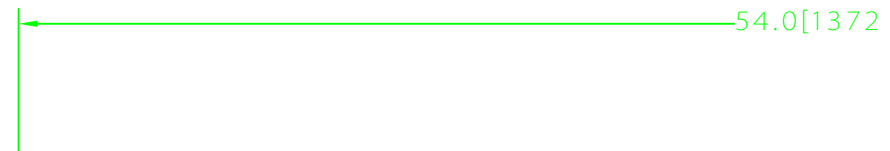
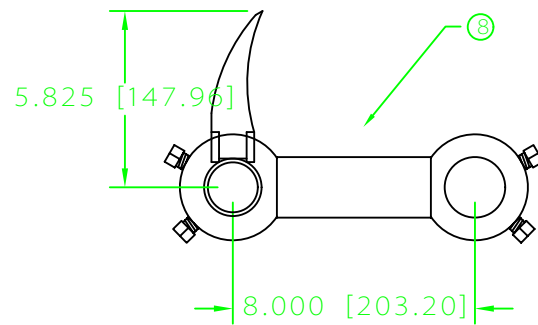

REVISIONS

A	SH	022502	ADDED PART NUMBERS
B	CF	110707	CHANGED LAYERS



BELT TRAVEL

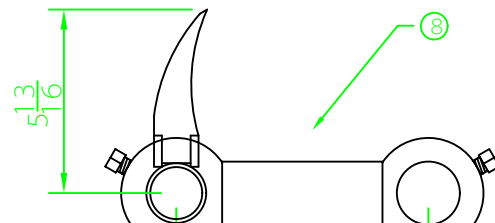

REVISIONS			
A	SH	022502	ADDED PART NUMBERS
B	CF	110707	CHANGED LAYERS

ITEM	QTY.	DESCRIPTION	PART #
1	1	GORDON SABER BLADE	MRBGS00060F000
2	1	URETHANE TENSIONER	MCBTRD00300
3	1	BLADE HOLDER ASSEMBLY	MFRSC00060F00060F0000
4	1	SUPPORT / TENSIONER PIPE	MCBRTP11000
5	1	SHEAR PIN	MCBRIP00000
6	1	WELD COLLAR	MCRHSU00000
7	1	WRENCH NOT SHOWN	MCRW000000
8	2	PIVOT ARM	PA-014-8AL

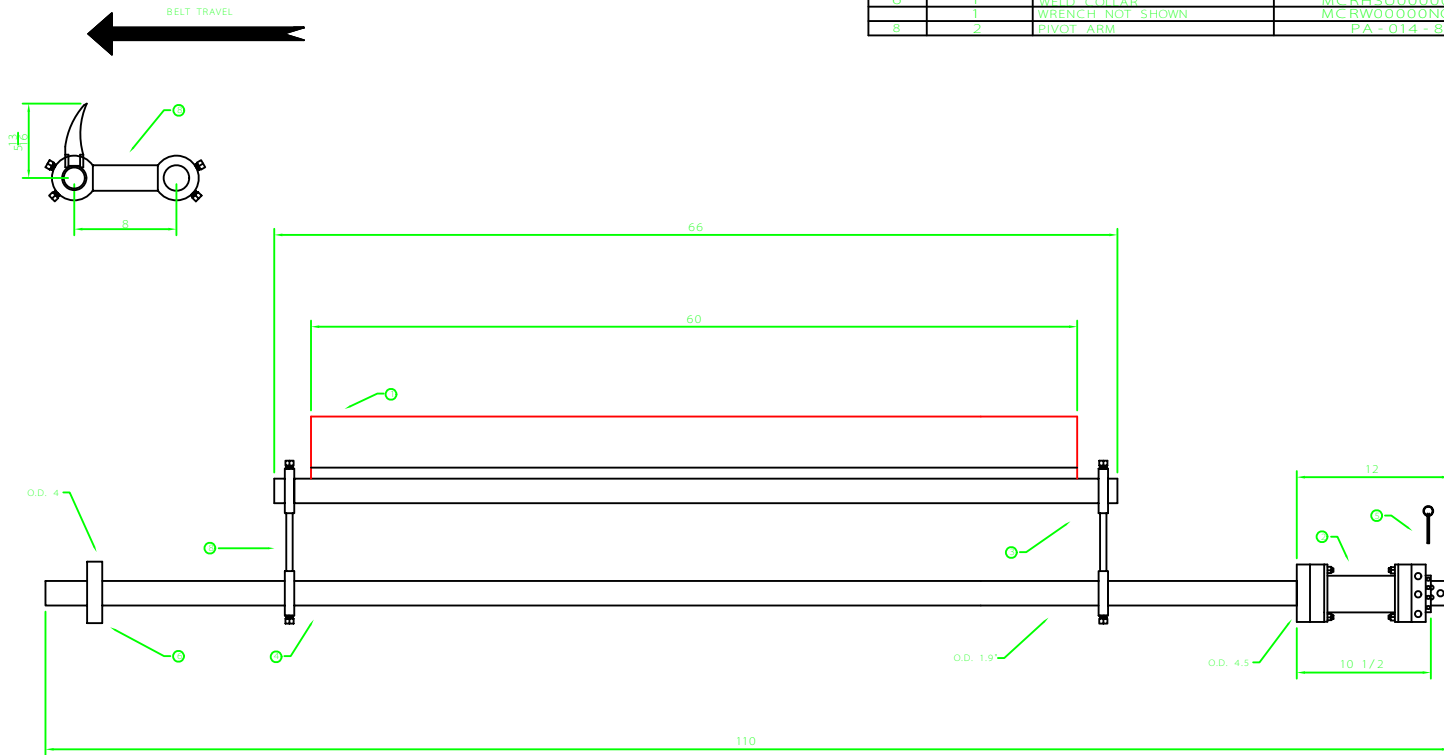

FILENAME= GSS - 60  
 PLOTSCALE=1=4

ARCH ENVIRONMENTAL EQUIP., INC.			
GORDON SABER GSS - 60 - UR - TA SECONDARY CLEANER			
DRAWN: S.HOWARD	DATE		
CHECKED: G.A.W.	DATE		
APPROVED: N.E.A.	DATE		
SCALE	JOB No.	DRAWING NO. 112092R	SHEET OF REV. A

REVISIONS			
A	SH	022502	ADDED PART NUMBERS
B	CF	110707	CHANGED LAYERS

ITEM	QTY.	DESCRIPTION	PART #
1	1	GORDON SABER BLADE	MRBGS00072F000
2	1	URETHANE TENSIONER	MCRTRD00300
3	1	BLADE HOLDER ASSEMBLY	MFRSC00072F00072F0000
4	1	SUPPORT / TENSIONER PIPE	MCRPTP12200
5	1	SHEAR PIN	MCRRIP000NO
6	1	WELD COLLAR	MCRHSU00000
	1	WRENCH NOT SHOWN	MCRW00000NO
8	2	PIVOT ARM	PA - 014 - 8AL

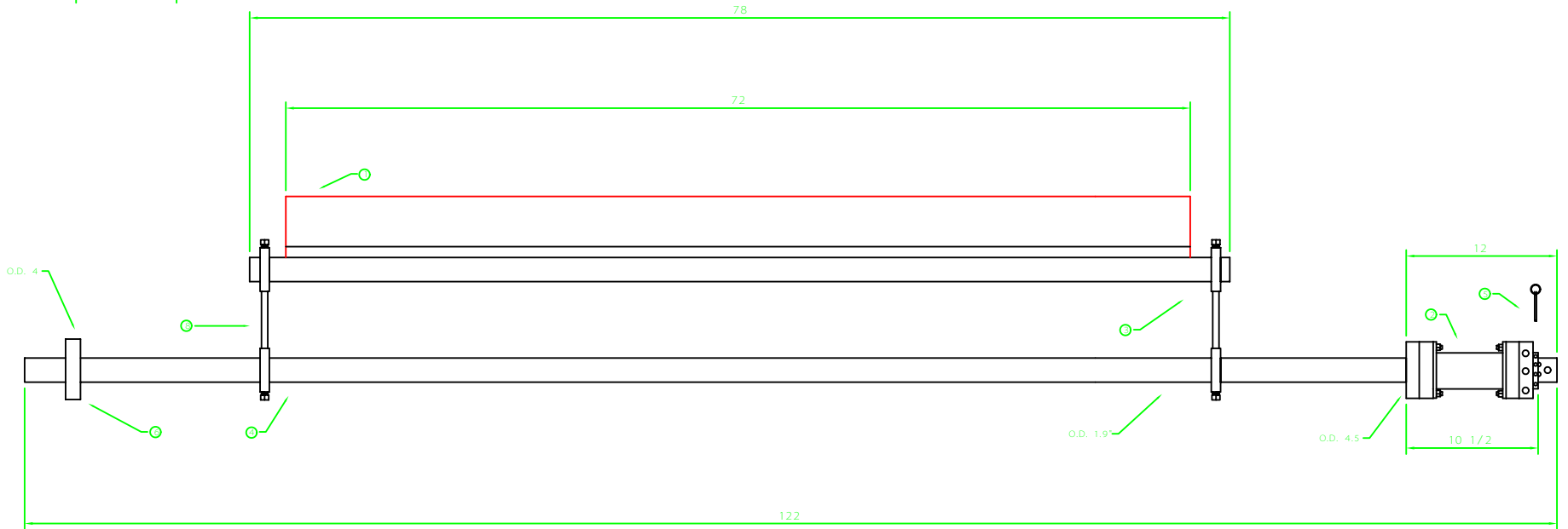
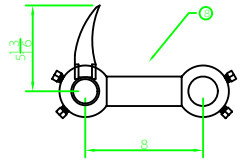

FILENAME= GSS - 72  
PLOTSCALE=1=4

DRAWN:	S. HOWARD	DATE:	
CHECKED:	G. K. W.	DATE:	
APPROVED:	N. F. A.	DATE:	
SCALE:		JOB No.	

ARCH ENVIRONMENTAL EQUIP., INC.			
GORDON SABER GSS - 72 - UR - TA SECONDARY CLEANER			
DRAWING NO.	112092R	SHEET	OF
REV.	A		

REVISIONS

A	SH	022502	ADDED PART NUMBERS
B	CF	110707	CHANGED LAYERS

ITEM	QTY.	DESCRIPTION	PART #
1	1	GORDON SABER BLADE	GSS - 016 - 72
2	2	URETHANE TENSIONER	GT - 017 - 3
3	1	BLADE HOLDER ASSEMBLY	BH - 015 - 78 - 1
4	1	SUPPORT / TENSIONER PIPE	GP - 019 - TBA
5	2	SHEAR PIN	GSR - 600 - 1A
6	OMIT	WELD COLLAR	GP - 010
	2	WRENCH NOT SHOWN	GP - 020
8	2	PIVOT ARM	PA - 014 - 8AL

BELT TRAVEL

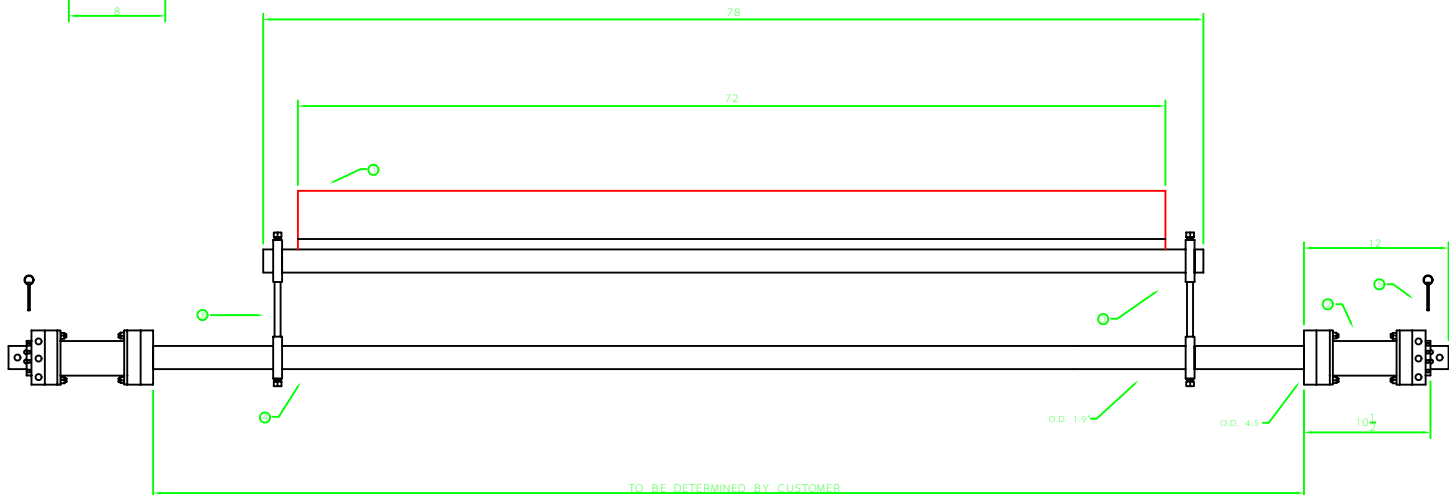
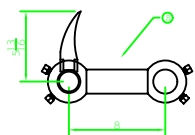

DRAWN	S. HOWARD	DATE
CHECKED	G. K. W.	DATE
APPROVED	N. F. A.	DATE
SCALE	JOB NO.	

ARCH ENVIRONMENTAL EQUIP., INC.		
GORDON SABER GSS - 72 - UR - DT SECONDARY CLEANER		
DRAWING NO.	102497F	SHEET OF REV. A