

Who is Arch Environmental?

*manufacturer and worldwide distributor of preferred bulk conveyor components since 1975

Mechanical Division

Belt Cleaners • Belt Alignment • Sealing Systems • Dust Control Systems • Impact/Slider Systems

Electrical Division

Belt Scales • Metal Detectors • Pull Cord Switches • Belt Protection Devices • Conveyor Control Systems

*facilities include a fabrication shop, a CNC machine shop, and state-of-the-art urethane production



Patented *Twister Tensioners*® maintain consistent blade-to-belt pressure and the cores are **GUARANTEED FOR LIFE!**

Two *Saber Channel Mount*® primary cleaners mounted at the head pulley for extra defense against carryback.

Decreases cleanup costs by eliminating carryback BEFORE it reaches the ground.

Compact design easily installed in tight spaces.

Non-segmented blade is quickly replaced with single-pin removal.

Multiple blade options include

high-temperature, high-moisture, high-speed, and food-grade.

ARCH SABER DUAL PRIMARY® CLEANER

A narrower front cleaner that eliminates carryback off the center of the belt, backed by a second, wider cleaner to handle the edges.

Two curved, extremely tough polyurethane blades leave no doubt that belts are carryback-free.

- | | |
|------------------------|---|
| EZ Installation | ✓ |
| Low Maintenance | ✓ |
| Splice Safe | ✓ |
| Fast Delivery | ✓ |
| Heavy-Duty | ✓ |
| Superb Cleaning | ✓ |

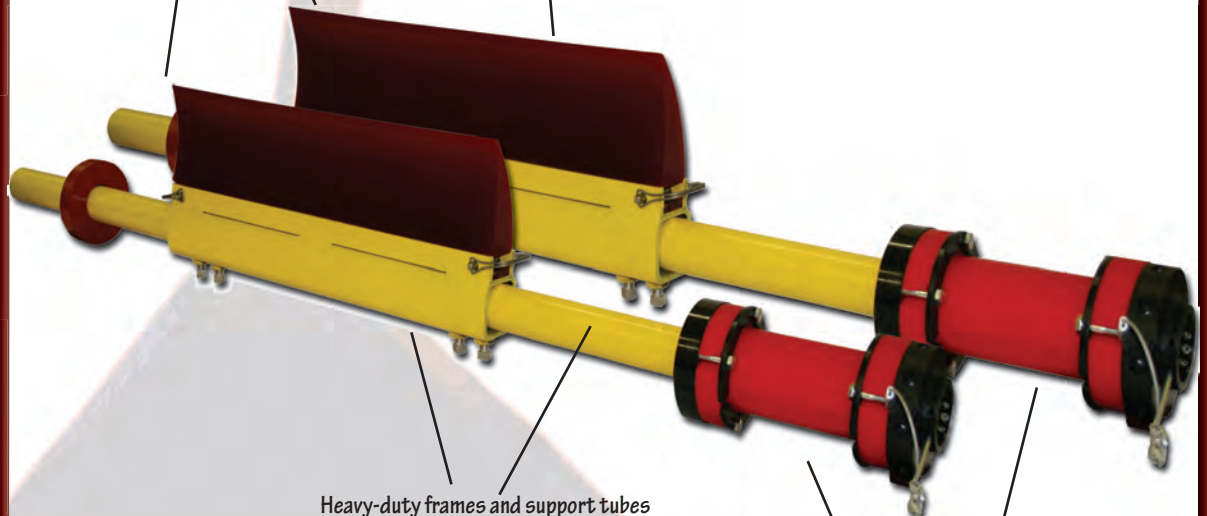

Heavy-duty frames and support tubes confront tough conditions with even tougher performance.

Each cleaner, of course, is armed with Arch's patented *Twister Tensioner*® that maintains optimum blade-to-belt pressure so you don't have to.

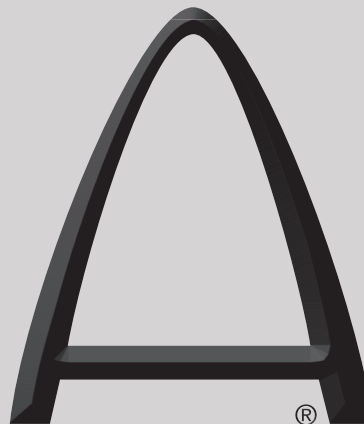

ARCH
ENVIRONMENTAL
EQUIPMENT, INC.

CONVEYOR EFFICIENCY SPECIALISTS

800-553-4567

www.archenv.com

(Conveying Confidence)

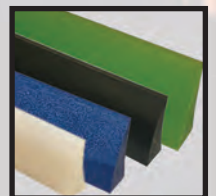

ARCH SABER DUAL PRIMARY CLEANER

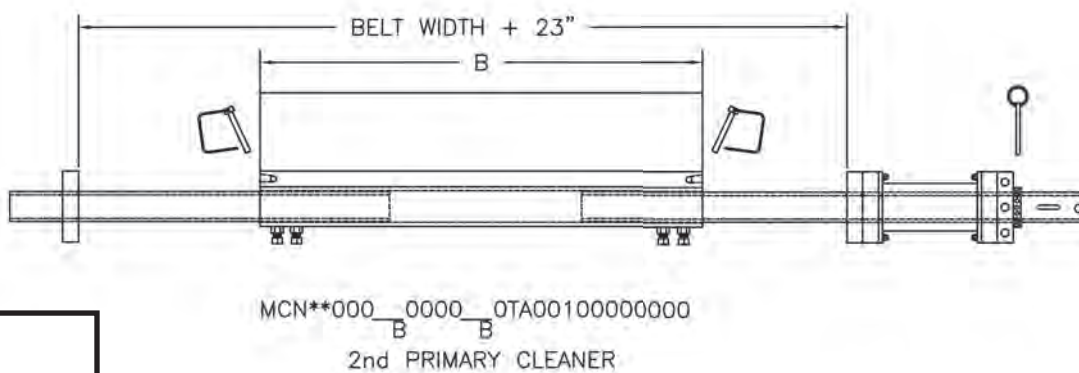
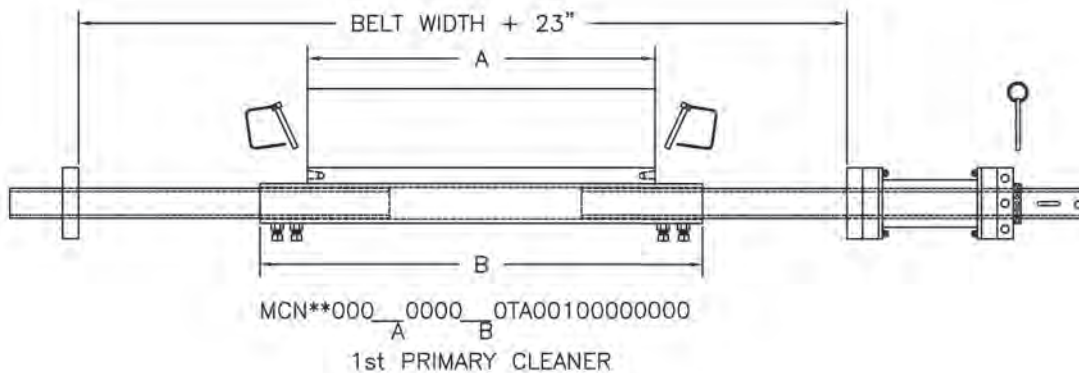

- Standard Blade
Red
Temp. Range: 180-220°F
- High-Moisture Blade
Gray
Temp. Range: 180-220°F
15%+ Moisture Content
- Ceramic Blade
Blue
High Friction/High Speed
750+ ft./min.
- High Temperature Blade
Green
Temp. Range: up to 300°F
- Non-pigment Blade
White
Same as Standard Red Blade
Ideal for color-sensitive material (ie. Borax, Soap, etc.)
- Food Grade Blade
Natural
FDA approved for mild contact with food products.

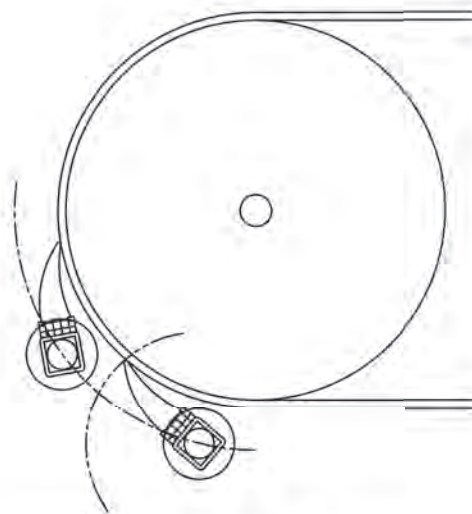

BELT CLEANER SELECTION GUIDE	
PULLEY DIAMETER	
24"	
160mm +	
18"-36"	
140mm-210mm	
4"-14"	
110mm-400mm	
BELT SPEED	
0-450 FPM	
0-2.5 m/s	
>50 FPM	
>2.5 m/s	

**INSERT SB-SABER PRIMARY CM-CHANNEL MOUNT PRIMARY MN-MINI PRIMARY



Covered under one or more of the following patents:
4,202,437;4,231,471;4,436,446;4,489,823;4,533,036;4,779,716;4,877,125;
4,989,727;5,149,305;5,222,588;5,222,589;5,219,063;5,350,053;5,725,083;
other patents pending

Note: If available, prices vary with options.