

Arch Environmental Equipment, Inc. GORDON SABER PRIMARY BELT CLEANER

INSTALLATION INSTRUCTIONS

THE TOOLS & RESOURCES REQUIRED ARE:

- | | |
|------------------|-------------------------|
| 1. TAPE MEASURE | 5. ADJUSTABLE WRENCH |
| 2. STRAIGHT EDGE | 6. WELDING EQUIPMENT |
| 3. CUTTING TORCH | 7. CHALK |
| 4. LEVEL | 8. STRING (36" or more) |

***SHUT DOWN AND LOCKOUT CONVEYOR BEFORE
PERFORMING ANY MAINTENANCE***

STEP 1

Determine the diameter of the head pulley and the thickness of the conveyor belt.
Example: head pulley diameter = 24" (609.6mm), belt thickness = $\frac{3}{4}$ " (19.05mm). Take one half of the head pulley measurement (in this case 12" (304.8mm)) and add the belt thickness. This will give an effective radius of $12\frac{3}{4}$ " (323.85mm).

STEP 2

To this number add dimension "A" (either $2\frac{3}{4}$ " (69.85mm) or $3\frac{1}{2}$ " (88.9mm)). To determine dimension "A" (spacing from the face of the belt), you must first determine the head pulley diameter. If the pulley diameter is 22" or smaller, then an "A" dimension of $3\frac{1}{2}$ " (88.9mm) should be used. If the head pulley diameter is larger than 22", use an "A" dimension of $2\frac{3}{4}$ ". This will give you the "Z" dimension. See fig. 1. To assist you in achieving this spacing, urethane "installation rings" have been included with the cleaner (see figure 3). Use these as directed in step 7.

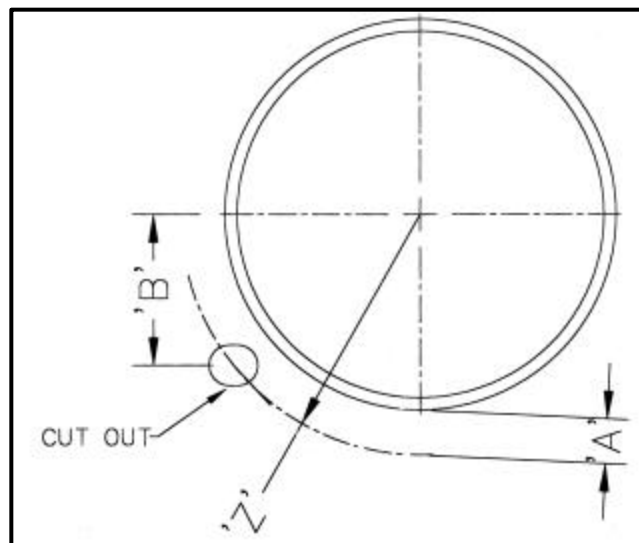

Fig. 1

STEP 3

Using the “Z” dimension as described in step 2., use the string and chalk to draw an arc (with radius of “Z”) to define the area for cutting the mounting holes on the chute wall.

STEP 4

From the centerline of the head pulley measure down $9\frac{1}{2}$ ” (241.3mm) (SEE FIG. 1, Dimension “B”). This is the highest point that the cleaner should be mounted. It can be mounted anywhere along the radius that was marked off in step 3. The limiting factor is the restriction of a dribble chute or lack of a dribble chute at the point where the belt leaves the head pulley on the return side. Note: DO NOT install the cleaner within the trajectory of the material.

STEP 5

After you have located the correct position to mount the cleaner, mark two holes approximately $2\frac{1}{2}$ ” (63.5mm) x 3” (76.2mm) in size. These should now be torched or cut out. Note: DO NOT use existing holes from another brand of cleaner.

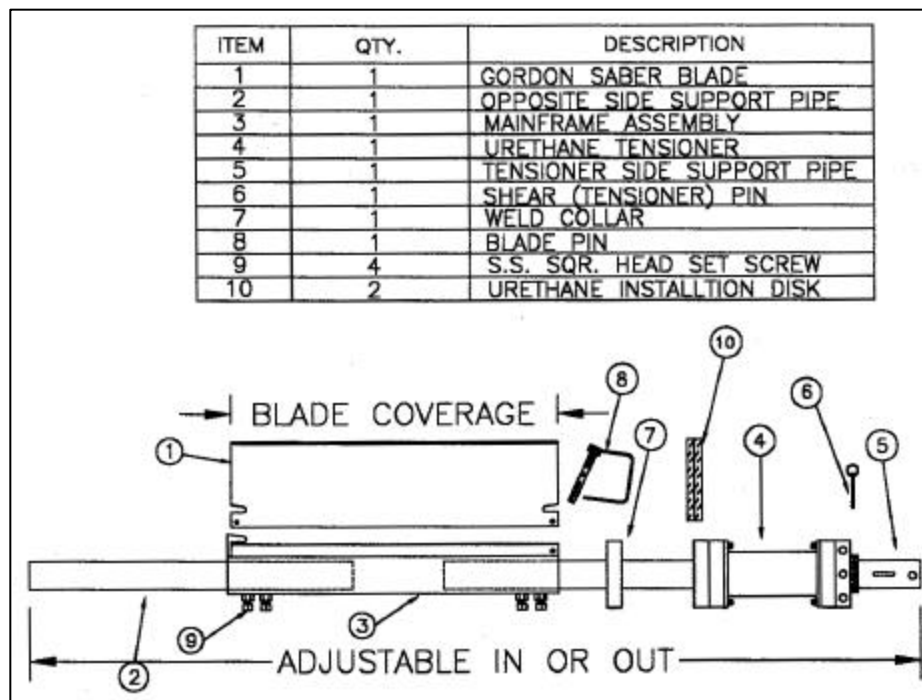

Fig. 2

STEP 6

Disassemble the cleaner (FIG. 2). This is done by removing the pin (ITEM 6) at the end of the tensioner hub. Remove the tensioner (ITEM 4 - FIG. 2) from the tensioner pipe. You will notice whenever the tensioner is removed, there is another weld collar (ITEM 7 - FIG. 2). This is the weld collar for the opposite side and installation rings to verify the “Z” and “A” dimensions. The two urethane rings (ITEM 10 - FIG. 2) and tensioning instructions will be found packaged to the cleaner. You will also find the tensioner wrench inside the tensioner pipe. Loosen the setscrews (ITEM 9 - FIG. 2) on the mainframe. **Caution! Loosen them only enough to allow both pipes (ITEMS 2 & 5 - FIG. 2) to be removed from the cleaner mainframe (ITEM 3 - FIG. 2).**

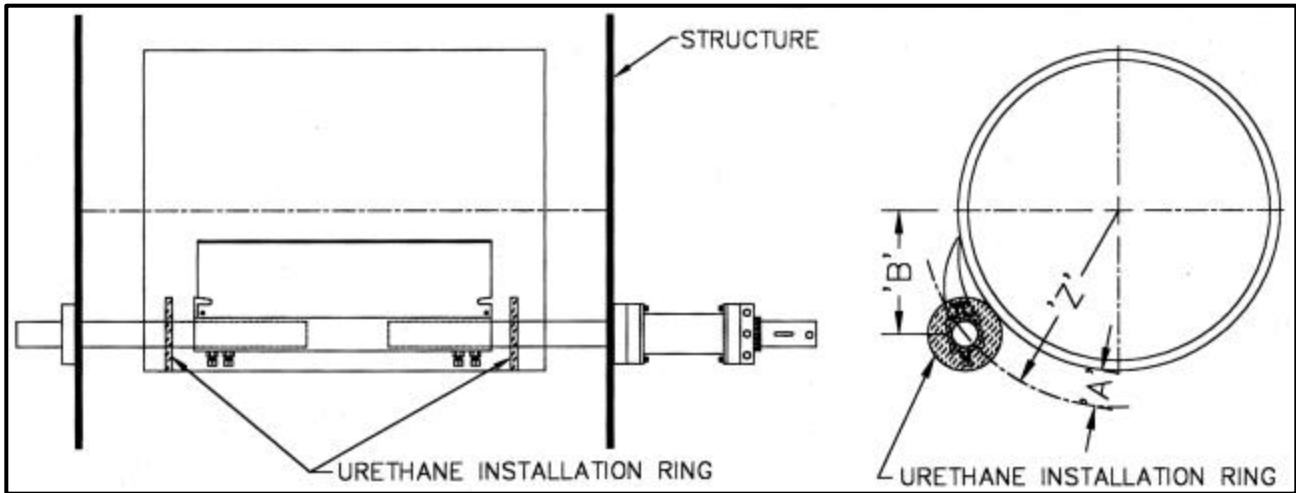

Fig. 3

STEP 7

Put the frame and blade assembly (ITEMS 1 & 3 - FIG. 2) inside the chute, and slide the support pipes (ITEMS 2 & 5 - FIG. 2) through the 2 ½" (63.5mm) x 3" (76.2mm) holes previously cut. Then slide the weld collar (ITEM 7 - FIG. 7) and the tensioner (ITEM 4 - FIG.2) onto the support & tensioner pipes. Next, level the cleaner in relation to the head pulley. Verify the "Z" dimension by slipping the installation rings (see figure 3) onto the support & tensioner pipe. If the head pulley diameter is larger than 22", remove the outer ring. The installation ring should be placed against the belt. Tack weld the weld collar and tensioner into place. Set the cleaner blade against the belt and insert the pin (ITEM 6 - FIG. 2) into the tensioner hub. Tighten the setscrews on the mainframe and complete welding on the hubs (3-1" (25.1mm) welds on each hub is enough). Pull the pin again to check if the cleaner rotates freely in the hubs; if it doesn't, realign the hubs until it rotates freely.

STEP 8

Finally, pull the pin (ITEM 6 - FIG. 2) and rotate the tensioner away from the head pulley, until the next hole shows (SEE FIG. 4) in the tensioner hub. Reinstall the pin.

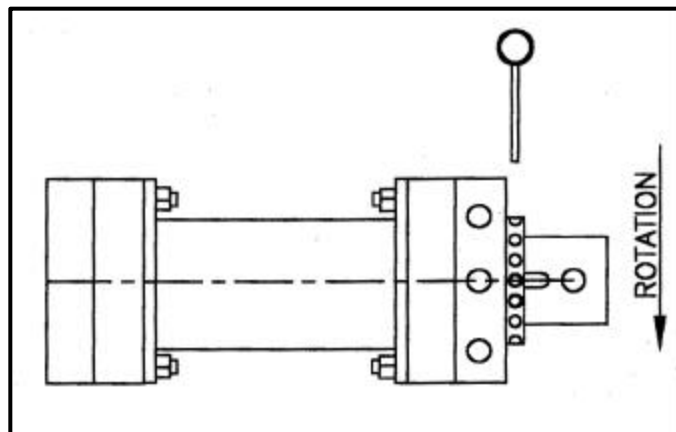
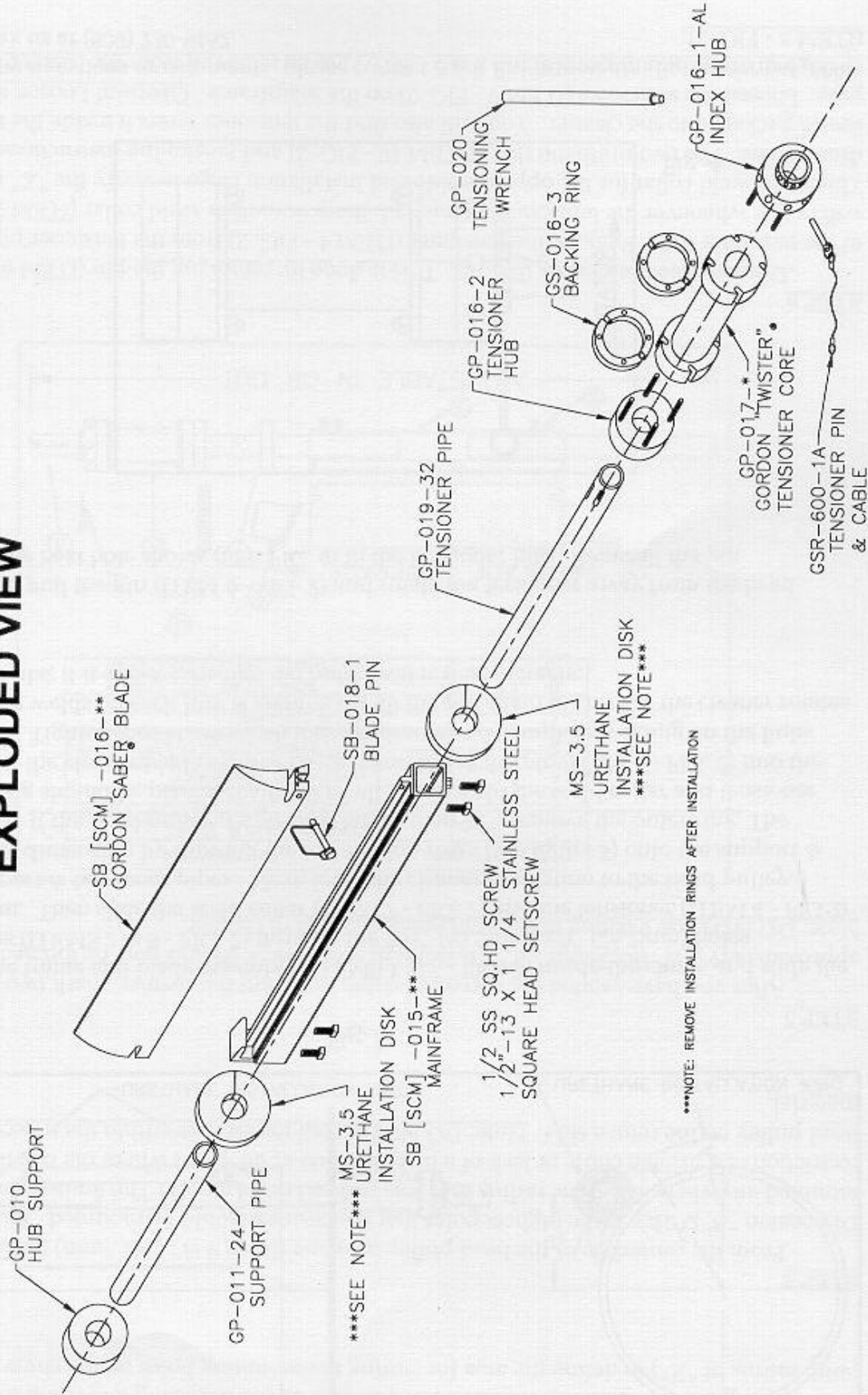

Fig. 4

If there are any questions or comments, please contact Arch Environmental Equipment at (800) 553-4567 or fax us at (800) 230-9462.

Thank you for using Arch Environmental Equipment products!

GORDON SABER BLADE BELT CLEANER EXPLODED VIEW



Phone: 800-553-4567 / Fax: 800-230-9462