

ArchWeigh 2000

Conveyor Belt Scale Weigh Idler
For Single or Multiple Scale Bases

Installation & Operation Manual

Rev. 11/04

Post Office Box 1760 5929 Benton Road Paducah, KY 42002-1760
PHONE: 800-553-4567 FAX: 800-230-9462
<http://www.aeec.com>

ArchWeigh Belt Scale Installation and Operation

Table of Contents

Item:	Page:
RECOMMENDED TOOLS FOR INSTALLATION.....	3
ELECTRICAL CONNECTIONS.....	8
TERMINAL STRIP AT THE INTEGRATOR.....	10
NOTE:	11
SETUP OVERVIEW.....	13
SETUP:.....	13
<i>Roller Diameter</i>	<i>13</i>
<i>Number of Revolutions per pulse.....</i>	<i>13</i>
<i>Tonnage Measurement</i>	<i>13</i>
<i>Weigh Area Span.....</i>	<i>13</i>
<i>Reset Master Totalizer.....</i>	<i>13</i>
<i>Maximum Rate.....</i>	<i>13</i>
<i>Auto Tare.....</i>	<i>13</i>
<i>Calibration Constant.....</i>	<i>13</i>
CALIBRATE:	14
<i>Set Dead Weight</i>	<i>14</i>
<i>Enter Test Weight.....</i>	<i>14</i>
<i>Set Test Weight</i>	<i>14</i>
TARE:	14
PERFORM MATERIAL TEST OR FTEST	14
MENU DESCRIPTIONS:.....	15
SETUP AND OPERATION SCREENS:.....	15
<i>Main:</i>	<i>15</i>
<i>Setup Menu:.....</i>	<i>17</i>
<i>Setup Menu Page Two:.....</i>	<i>18</i>
<i>Calibrate Screen One:</i>	<i>19</i>
<i>Calibrate Screen Two:.....</i>	<i>20</i>
<i>Calibrate Screen Three:</i>	<i>21</i>
<i>Belt Tare:.....</i>	<i>22</i>
<i>Belt Tare Procedure</i>	<i>22</i>
<i>Raw Analog:.....</i>	<i>23</i>
<i>Calibrations:</i>	<i>24</i>
<i>Large Display:.....</i>	<i>25</i>
<i>Scale Selector:</i>	<i>26</i>
APPENDIX:	27
TERMINAL STRIP LAYOUT	27
BASIC WIRING SCHEMATIC	28
WIRING DIAGRAM	29
ANALOG OUTPUT.....	30
TARE FLOWCHART	31
CALIBRATE FLOWCHART	32

Recommended Tools for Installation

Butt Splice Crimpers

Utility Knife or Wire Strippers

½” Drill for drilling and mounting conduit or wire grips to the scale and Integrator

Socket set and wrenches for mounting Scale and Integrator

Small flat tipped screwdriver for connecting conductors in Integrator

ArchWeigh Belt Scale Installation and Operation

Mechanical Installation:

Definitions: (See Figure 1)

Load Area: Any area covered by skirtboard material.

Scale Area: Area from the minus three approach idler to the plus three retreat idler.

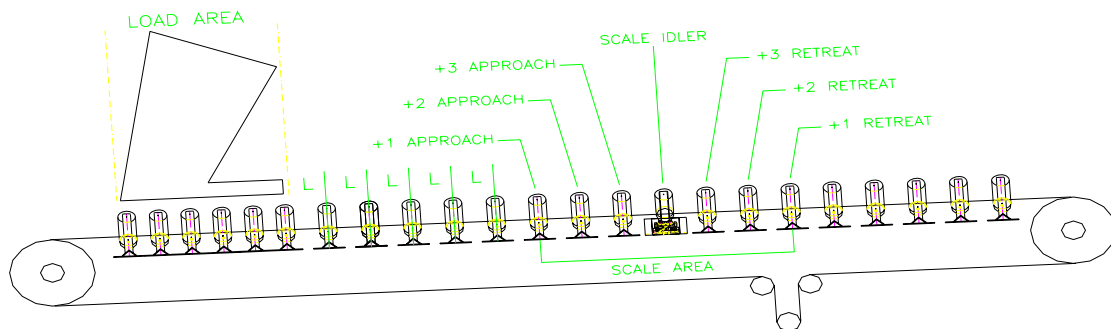

Figure 1

Location:

- The weigh idler should be installed at a point where material speed and belt speed match; generally within 50 feet of the load point, but no closer than 5 idlers of the load area.
- If the scale assembly is to be mounted on a conveyor containing a curve, the weigh idler should not be installed within 40 feet of the curve.
- The conveyor should be rigid, or bracing must be added to strengthen the framework.
- Scale assemblies should be located in areas with minimum vibration.
- Training idlers should not be located within 60 feet of the scale area.
- All idlers within the scale area must be in good condition and of the same make and model. In addition, T.I.R. must not exceed +/- 0.015 inch.
- The entire scale area should be protected from the elements as much as possible.
- Idler spacing within the scale area should conform to CEMA standards based on material conveyed, speed, etc.

ArchWeigh Belt Scale Installation and Operation

Installation: (See Figure 2)

Scale Assembly:

- 1) If necessary, strengthen the conveyor framework.
- 2) Any separations (expansion joints) of the conveyor stringers near the scale must be rigidly welded together.
- 3) Insure that the conveyor is level from the minus 3 approach idler to the plus 3 retreat idler.
- 4) Raise or remove the belt over the entire scale area (from minus 3 approach to plus 3 retreat).
- 5) Remove the idler located in the scale position and replace with the ArchWeigh scale assembly.

WARNING: Remove the shipping pins when the scale is sitting in place. (The idler will drop approximately ¼ inch when the shipping pins are removed. It will be impossible to correctly shim the idler until the shipping pins are removed.)

- 6) Locate and mark the mid point of the wing rolls of each idler assembly located in the scale area.
- 7) Square the minus two approach and the plus two retreat idlers with the conveyor structure.
- 8) Raise the minus three approach and the plus three retreat idlers 1/4 inch above the belt line.
- 9) Evenly space all idlers (including scale assembly) located between the minus three approach and the plus three retreat idlers.
- 10) Tie four lines (a piano wire or equivalent) to the base of the minus three approach idler; one line running across the center marks of each wing roll and two lines evenly spaced and running across the center roll. Each line should then be tied tightly to the base of the plus three retreat idler. (Note: On scale systems over 54 inches, an additional string line should be placed on each wing roll for a total of 6 lines.) Refer to figure 2.

ArchWeigh Belt Scale Installation and Operation

- ❑ 11) At this point in the setup process the lines should only touch the plus three and minus three idlers. The other idlers should be below the lines. If the line touches any roll located in the scale area, additional 1/16 inch shims should be evenly added to the minus three and plus three idlers until a clearance exists.

- ❑ 12) Shim all idlers between the plus three and minus three idler including the scale idler to within 1/32 inch of the lines but not touching the lines.

- ❑ 13) Insure that all idlers are squared, leveled, and bolted tightly in place.

- ❑ 14) See *Figure 3* - Tighten the load cells to the weight transfer bars.

- ❑ 15) See *Figure 3* - Loosen the Pivot Pin one (1) turn, loosen the Positioning Bolts two (2) turns. Tighten the Positioning Bolts and then tighten the Pivot Bolt. This procedure removes any torsion strain placed on the assembly during installation.

- ❑ 16) Remove all alignment strings.

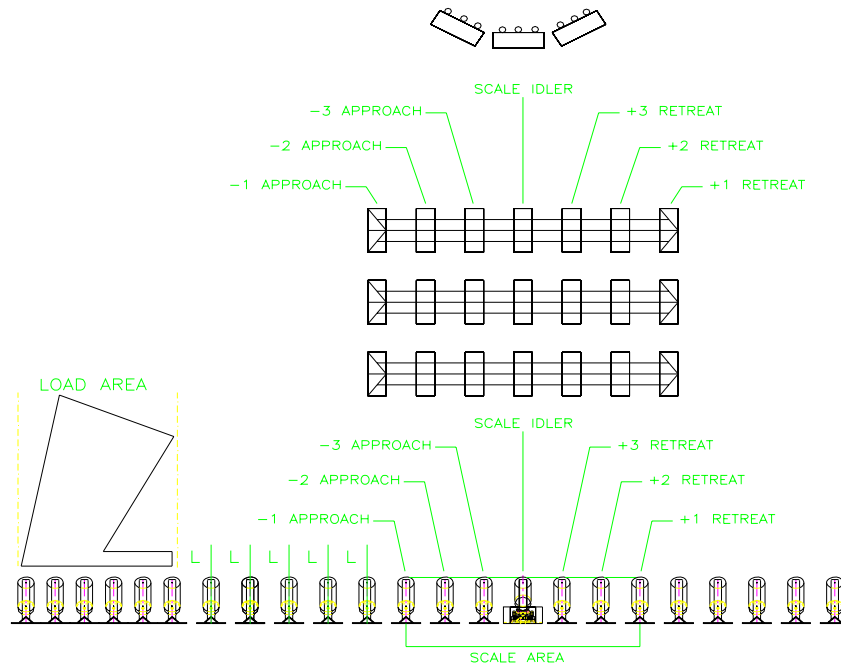

Figure 2

ArchWeigh Belt Scale Installation and Operation

After the scale is in place and the shipping pins have been removed tighten the weight transfer, mounting plate, and positioning bolts inside the loadcell enclosures on each end of the scale.

WARNING: Ensure that the scale shipping pins have been removed before tightening the bolts mentioned above or the loadcells may become damaged and/or the scale will not function properly.

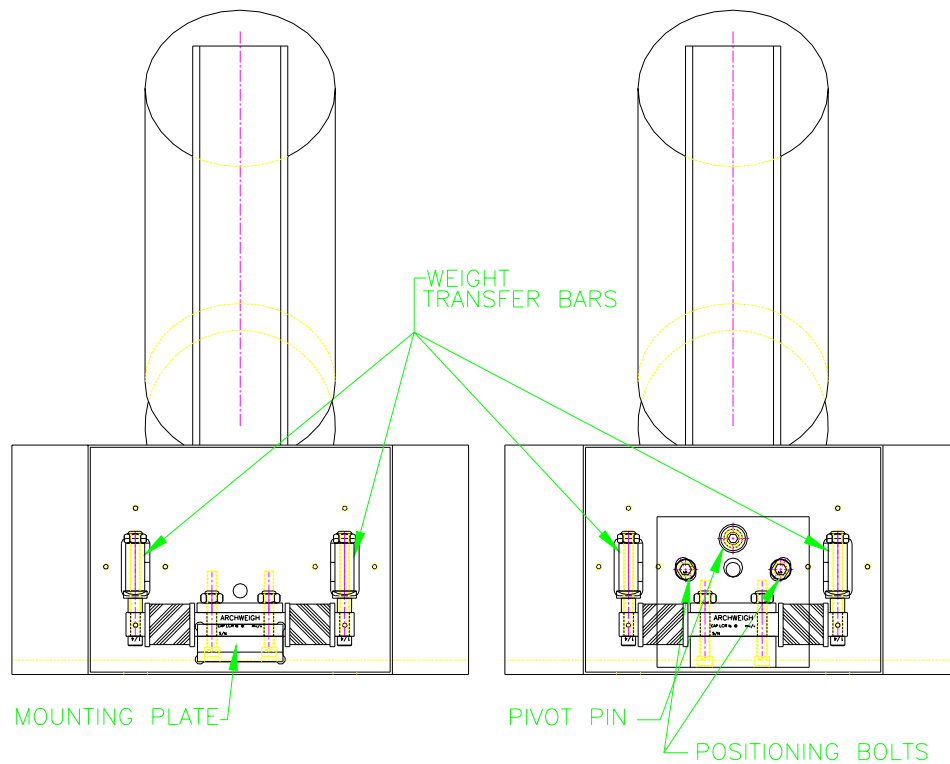

Figure 3

ArchWeigh Belt Scale Installation and Operation

Electrical Connections

Once the Scale has been installed and the integrator mounted in its desired location, the electrical connections can be made. All ArchWeigh Scales are shipped with 25 feet of loadcell cable (Belden Cable P/N 8723, 22 AWG Individually Shielded Pairs).

The loadcells use four conductors and a shield, while the Speed Sensor uses 3 conductors. This will allow you to mount the Integrator 10–12 feet from the Scale. If you require the Integrator to be located farther from the scale ARCH can provide you extra cable, at an additional cost, or you may wish to use the above part number to buy it locally in your area.

ArchWeigh Belt Scale Installation and Operation

Starting at the Scale

You will find the two loadcell wires and one speed sensor wire coiled up in the loadcell enclosure closest to the speed sensor. See diagram below:

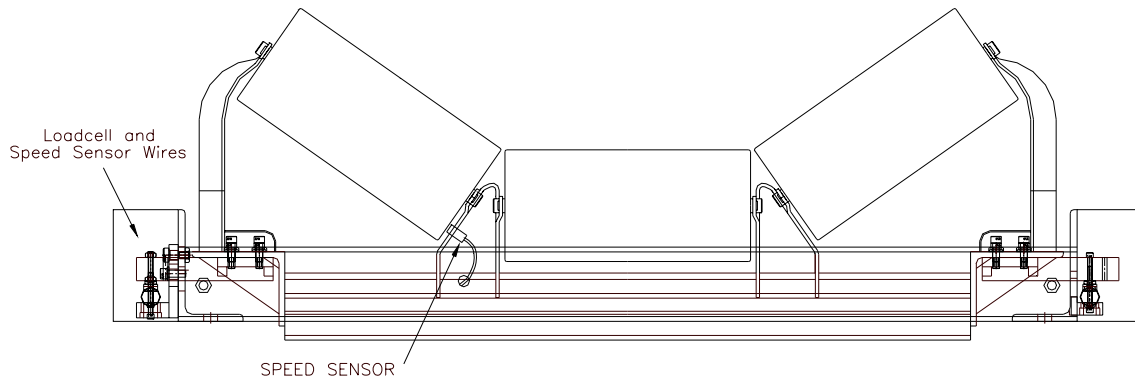

Remove the loadcell enclosure cover and uncoil the wires.

WARNING: ***Do not cut the loadcell wires***, they have been manufactured to compensate for temperature variances.

Cut the supplied Belden cable in half and insert one end of each cable through the side of the loadcell enclosure.

Remove approximately two (2) inches of the cable jacket from both ends of each cable that you inserted into the loadcell enclosure.

3. Cut the Speed sensor cable in the junction box so approximately 8 inches of cable is extending out from the hole in the back of the box.

4. Remove approximately two (2) inches of the cable jacket from the Speed Sensor cable.

Strip $\frac{1}{4}$ " of insulation off all the colored conductors.

NOTE: The Loadcell conductors have been pre-tinned at the factory.

6. Run the Cable to the integrator and make final electrical connections. See Diagram.

ArchWeigh Belt Scale Installation and Operation

Terminal Strip at the Scale Idler

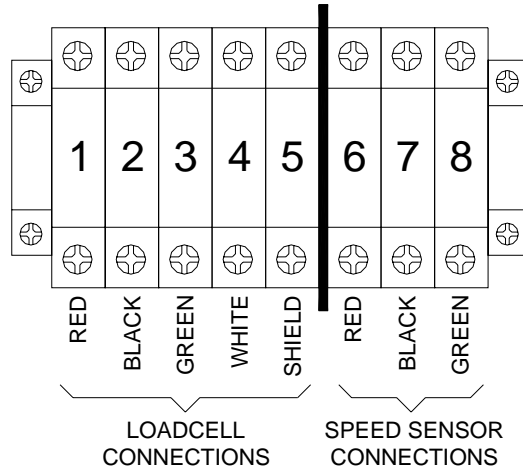

Terminal Strip at the Integrator

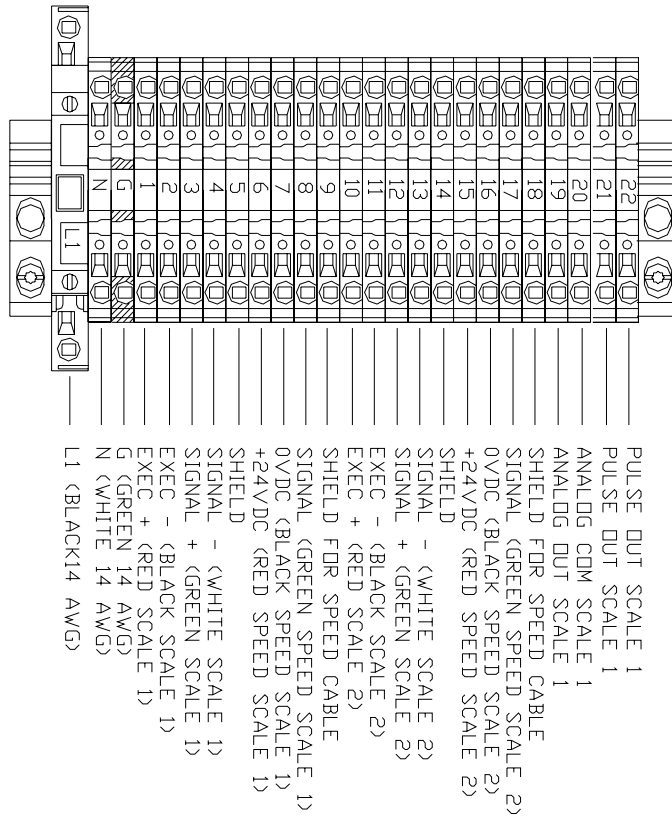

ArchWeigh Belt Scale Installation and Operation

Note:
Make sure that the Belt is off of the scale and clear of material before starting the calibration part of the scale setup.

ArchWeigh Belt Scale Installation and Operation

Once the ArchWeigh Conveyor Belt Scale has been mechanically installed and all electrical connections have been terminated, as specified in the previous section, there are four basic steps which must be performed to calibrate the Belt Scale and the electronic integrator.

- 1. SETUP**
- 2. CALIBRATE**
- 3. TARE**
- 4. MATERIAL TEST**

Each of these steps is described in the following section entitled: Setup Overview

ArchWeigh Belt Scale Installation and Operation

Setup Overview

Perform functions in the following order. The functions are accessible from the main menu of each scale.

Setup:

Roller Diameter

Enter the diameter of the roller or scale idler that the speed pickup is mounted to.

Number of Revolutions per pulse

Generally set by factory technicians to 14.

Tonnage Measurement

Choose the tonnage measurement to use.

Weigh Area Span

The distance in inches from the idler before the scale idler to the idler after the scale idler divided by two. (should equal idler spacing)

Reset Master Totalizer

Reset the master totalizer

Maximum Rate

Enter the Maximum rate that the conveyor will transport. Used to scale 4-20 Ma rate output.

Auto Tare

During initial setup this value will be set to 0. After initial setup set auto tare to a value in pounds that is greater than the minor weight variations on the scale and less than the lightest weight of continuous flow on the belt. If weight remains below the Auto Tare value for three revolutions a new tare value is established.

Calibration Constant

Compensation factor for adjusting totalizer accumulation. Set to 1.0000 for initial setup. See appendix x for complete definition.

ArchWeigh Belt Scale Installation and Operation

Calibrate:

Set Dead Weight

The dead weight is performed with the belt lifted and no test weights on the scale.

Enter Test Weight

Enter the weight in pounds of the test weight used to calibrate the scale.

Set Test Weight

The test weight is performed with the belt lifted off the scale and the test weights applied to the scale idler.

Tare:

Identify a point on the belt that can be identified while the conveyor is running. Run the conveyor for 30 minutes to insure that the belt is free of wrinkles created by the belt sitting idle on the idlers. Select engage tare to start the process. Press “Press when mark passes” each time the identified point passes the scale. After five revolutions of the belt the integrator will calculate a tare.

Perform material test or Ftest

The most reliable form of testing of the belt scale is to perform a material test. The material test involves running a known amount of material across a scale and comparing the scale’s total with the known.

In some situations the material test is not feasible. In these situations the Functional test can be used. To use the functional test apply test weights to the scale beneath the conveyor belt. In the Ftest setup enter the weight in pounds of the applied weight. Use the reset/begin button to start the test. The Ftest screen displays the accumulated total (scale weight) with the weight applied (known weight) and a calculated total based on the weight entered in Ftest setup.

The purpose of the test is to determine a calibration constant. See Appendix x for the formula for the calibration constant.

At this point the Belt scale should be ready for operation.

ArchWeigh Belt Scale Installation and Operation

Menu Descriptions:

Setup and Operation Screens:

Main:

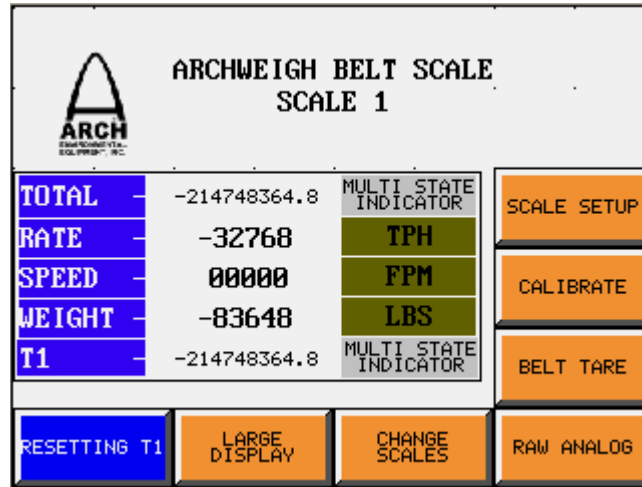

Main Screen Menu items:

Display:

Total

The running total.

Rate

Rate displayed in tons per hour.

Speed

Speed displayed in feet per minute.

Weight

Instantaneous static weight.

T1

Resettable total.

Function:

Ftest

Press to enter functional test setup. In some situations the material test is not feasible. In these situations the Functional test can be used. To use the functional test apply test weights to the scale beneath the conveyor belt. In the Ftest setup enter the weight in pounds of the applied weight. Use the reset/begin button to start the test. The Ftest screen displays the accumulated total with the weight applied and a calculated total based on the weight entered in Ftest setup.

ArchWeigh Belt Scale Installation and Operation

The purpose of the test is to determine a calibration constant. See the Appendix for the formula for the calibration constant.

Total T1 Only

Displays Total and T1 for the current scale in large characters.

Scale Setup

Press to enter setup screens to view/change setup parameters.

Calibrate

Press to enter static scale calibration screens.

Belt Tare

Press to enter belt tare screen.

Raw Analog

Press to view raw analog value.

Reset T1

Press to reset the resettable totalizer.

ArchWeigh Belt Scale Installation and Operation

Setup Menu:

SCALE SETUP PAGE 1 OF 2			
ROLLER DIAMETER	-	0	INCHES
NO. OF REVOLUTIONS PER READ	-	0	
TONAGE MEASUREMENT	LBS	TONS	CURRENTLY
	LONG TONS	METRIC TONS	MULTI STATE INDICATOR
WEIGH AREA SPAN	-	0	SETUP PAGE 2

Setup Menu Page One Items:

Roller Diameter

Press to change the diameter of the speed pickup idler/wheel.

Number of revolutions per pulse

Press to change the number of revolutions per input pulse. (usually set to 14 but is dependent on the factory setting of your A to D)

Tonnage Measurement

Press the desired tonnage measurement. Current tonnage measurement is displayed to the right.

Weigh Area Span

Press to change the span. Span is defined to be the measurement from the center of the idler before the scale idler to the center of the idler after the scale in inches, divided by two.

Setup Page Two

Press to view/change settings on page two of the setup menu.

ArchWeigh Belt Scale Installation and Operation

Setup Menu Page Two:

SCALE SETUP PAGE 2 OF 2 (SCALE 1)		
RESET MASTER TOTALIZER -	RESETTING	-214748364.8
MAXIMUM OUTPUT RATE -	1	
PERFORM FUNCTIONAL TEST -		DEFAULT ALL SCALE PARAMETERS
AUTO TARE (LBS) -	0	SETUP PAGE 1 OF 2
CALIBRATION CONSTANT -		SCALE SETUP PAGE 3

Setup Menu Page Two Menu Items:

Reset Master Totalizer

Press to Reset the master Totalizer. The current master totalizer is displayed to the right.

Maximum Output Rate

Press to set the maximum output rate. Used for scaling the 4-20 ma rate output.

Perform Functional test

Press to enter functional test setup. In some situations the material test is not feasible. In these situations the Functional test can be used. To use the functional test apply test weights to the scale beneath the conveyor belt. In the Ftest setup enter the weight in pounds of the applied weight. Use the reset/begin button to start the test. The Ftest screen displays the accumulated total with the weight applied and a calculated total based on the weight entered in Ftest setup.

The purpose of the test is to determine a calibration constant. See the Appendix for the formula for the calibration constant.

Auto Tare

Press to set a value in pounds. set auto tare to a value in pounds that is greater than the minor weight variations on the scale and less than the lightest weight of continuous flow on the belt. If weight remains below the Auto Tare value for three revolutions a new tare value is established.

Calibration Constant

Press to change the calibration constant.

Compensation factor for adjusting totalizer accumulation. Set to 1.0000 for initial setup. See the appendix for a complete definition.

Setup Page One of Two

Press to display page one of the setup menu

Default all Scale Parameters

Press to reset all scale parameters to factory default settings.

Return

Press to return to main screen.

ArchWeigh Belt Scale Installation and Operation

Calibrate Screen One:

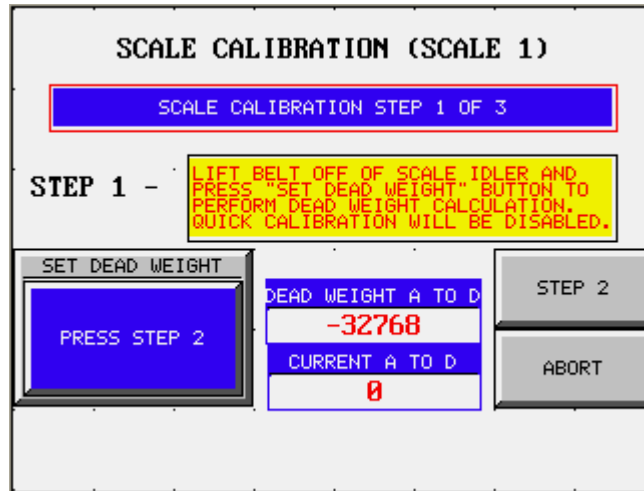

Scale Calibration Screen One Items:

Set Dead Weigh

Press to set dead weight.

Dead Weight A to D

Displays the Analog to Digital value of the Dead Weight.

Current A to D display

Displays current A to D value.

Step Two

Press to proceed to step 2.

Abort

Press to display Main Screen

ArchWeigh Belt Scale Installation and Operation

Calibrate Screen Two:

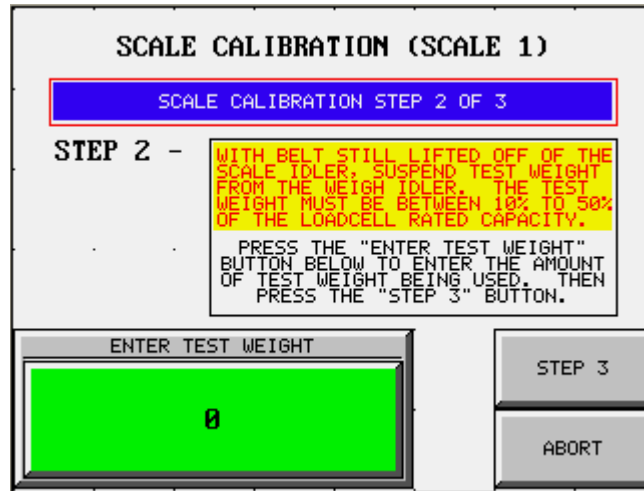

Calibration Screen 2 items:

Enter Test Weight

Press to Enter Test Weight to enter a the value of the test weights being used.

Step Three

Press to proceed to Step 3

Abort

Press to exit calibration

ArchWeigh Belt Scale Installation and Operation

Calibrate Screen Three:

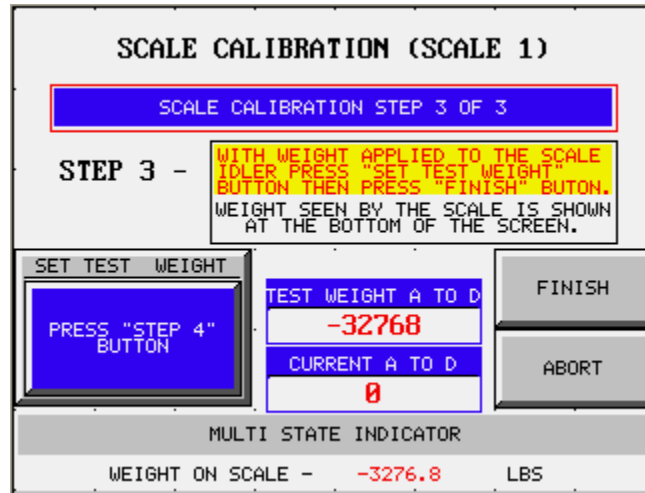

Calibrate Screen Three Items:

Set Test Weight

Press to set test weight

Test Weight A to D

Displays the A to D value for the test weight.

A to D Display

Displays Raw A to D value

Finish

Press to finish static calibration

Abort

Press to exit calibration

ArchWeigh Belt Scale Installation and Operation

Belt Tare:

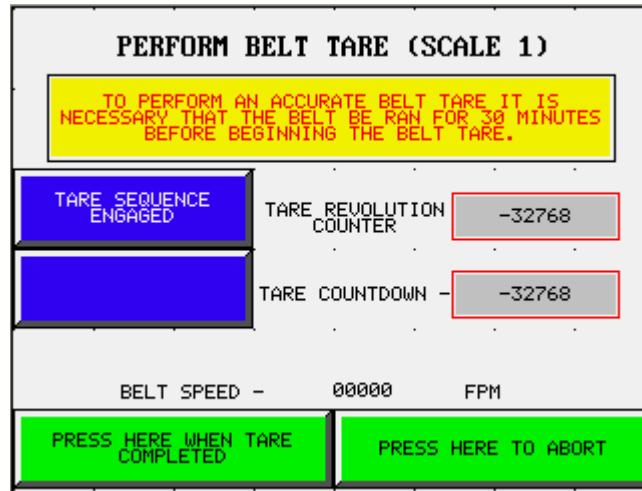

Belt Tare Screen Items:

Tare Sequence Engaged

Press to begin Tare.

Belt Revolution Input

Press when a belt revolution is completed

Tare Revolution Counter

Displays the number of completed revolutions of the belt.

Tare Countdown

Displays the calculated number of signals left to complete the current revolution of the belt.

Press Here When Tare is Completed

Displays Main Screen

Press Here to Abort

Displays Main Screen

Belt Tare Procedure

In order to properly tare the belt it is necessary to run the conveyor for 30 minutes to insure that any wrinkles created by the belt laying on the idlers have disappeared. Find or place an identifying mark on the belt that can be identified when the belt is running.

Press "Enable Tare to begin"

Press "Press When Mark Passes" as the identified mark passes the scale.

The Tare revolution counter will increment by one at each pressing of the "Press When Mark Passes" button.

Tare Countdown counts down to zero as the identified mark passes the scale.

After 5 revolutions the Integrator will calculate a new tare.

Press "Press Here When Tare Completed" to finish.

Press "Press Here to Abort" to abort.

To determine the accuracy of the tare, reset t1 and monitor it for at least five revolutions of the belt. It should remain at zero.

ArchWeigh Belt Scale Installation and Operation

Raw Analog:

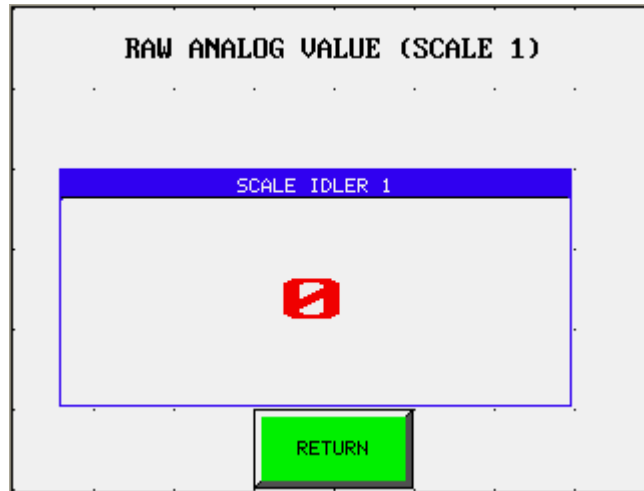

Raw Analog Screen Items:

Analog Value

Displays the Analog to Digital value received from the A to D converter

Return

Press to return to the main screen

ArchWeigh Belt Scale Installation and Operation

Calibrations:

CALIBRATIONS (SCALE 1)	
Multiple calibration constants can be useful on conveyors like stacking conveyors that can be raised or lowered. Just statically calibrate the scale at one of the positions of the conveyor and set a calibration constant for each of the others.	
CURRENT CALIBRATION	CURRENT VALUE
MULTI STATE INDICATOR	0.0000
CAL CONSTANT 1 - 0.0000	SET CURRENT
CAL CONSTANT 2 - 0.0000	SET CURRENT
CAL CONSTANT 3 - 0.0000	SET CURRENT
	RETURN

Calibrations Screen Items:

Current Calibration

Indicates which of the three calibration constants is in use.

Current Value

Indicates the value of the calibration constant being used.

Cal Constants

Three numeric entry buttons that display and allow editing of the three saved calibration constants. Press the constant to modify its value.

Set Current

Press the "Set Current" button to the right of any of the three saved Calibration Constants to make it active.

Return

Press Return to return to Scale Setup.

Multiple calibration constants can be useful on conveyors like stacking conveyors that can be raised or lowered. Just statically calibrate the scale at one of the positions of the conveyor and set a calibration constant for each of the others.

ArchWeigh Belt Scale Installation and Operation

Large Display:

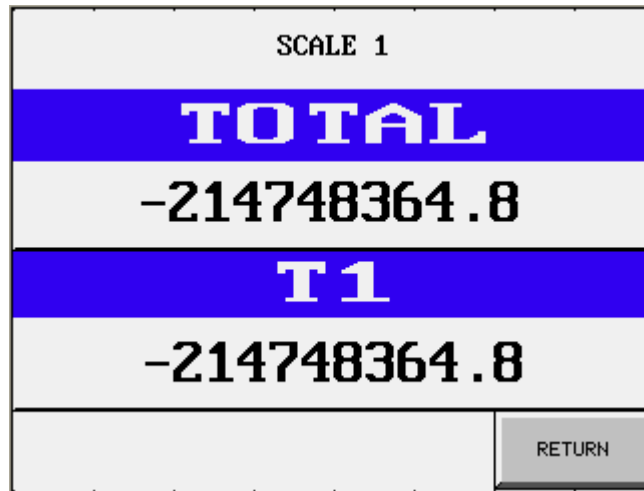

Displays Total and the resettable totalizer for the selected scale
Return

Press "Return" to return to the main screen.

ArchWeigh Belt Scale Installation and Operation

Scale Selector:

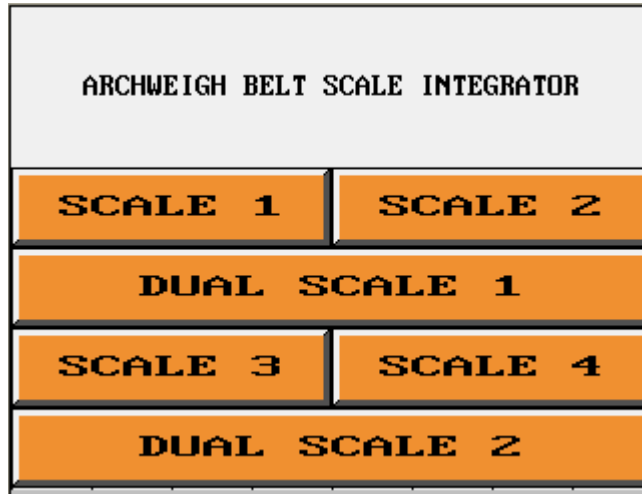

Press the button of the scale to view.

ArchWeigh Belt Scale Installation and Operation

Appendix: Terminal Strip Layout

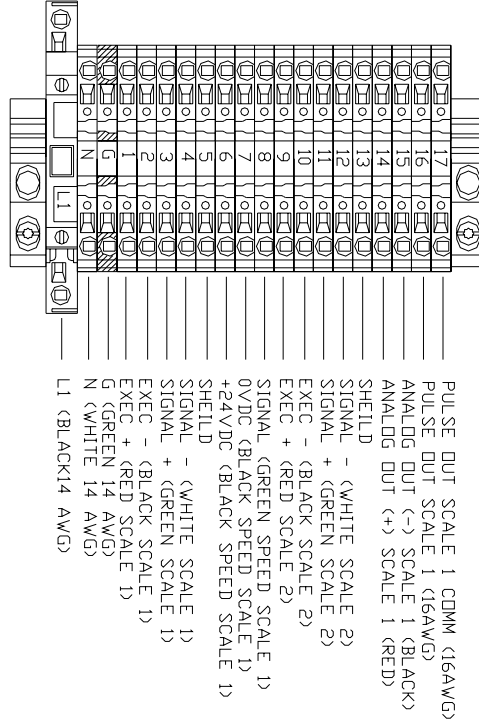

Basic Wiring Schematic

ARCHWEIGH BASIC WIRING SCHEMATIC

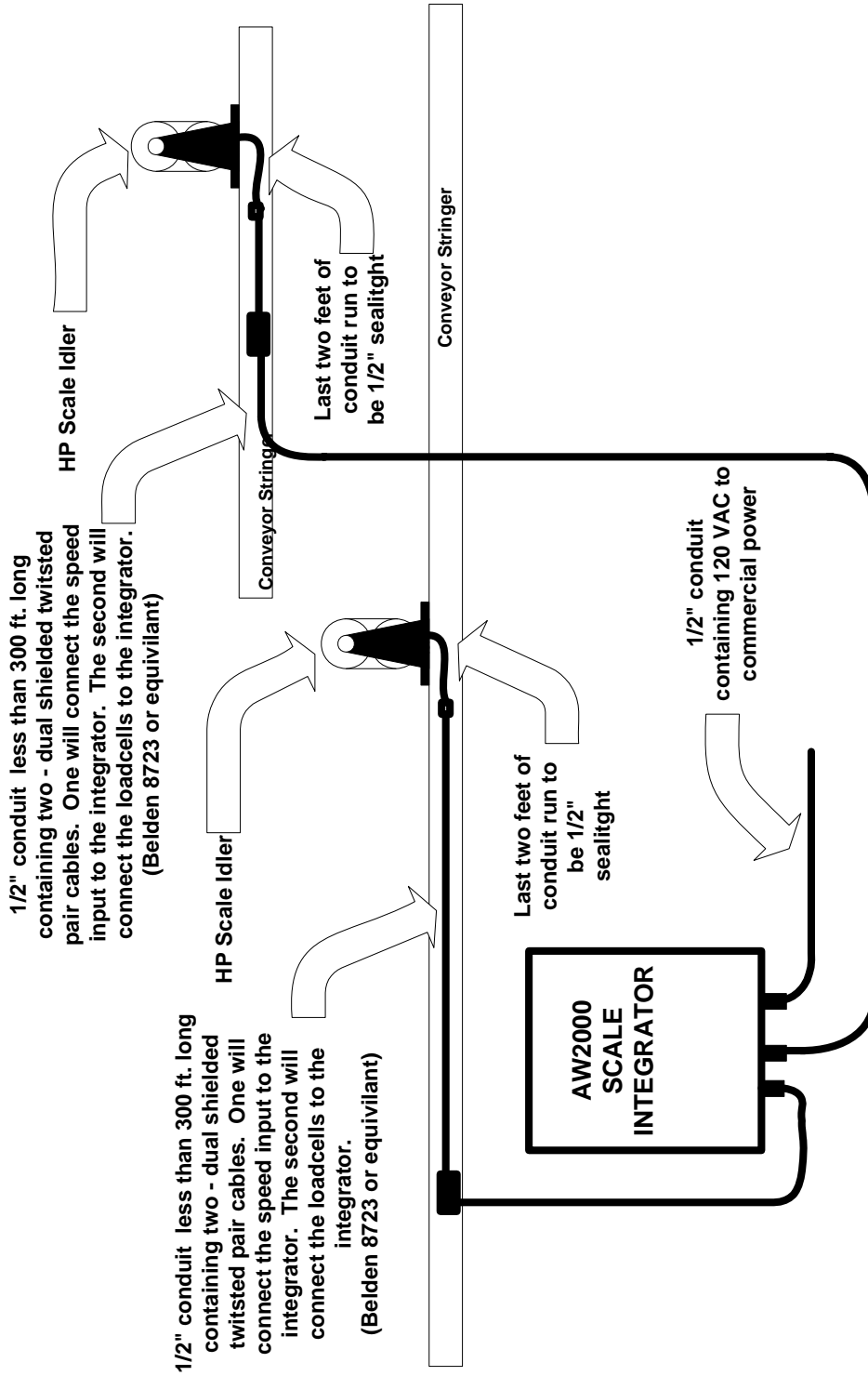

ARCH ENVIRONMENTAL EQUIPMENT, INC.
 P.O. BOX 1760 5929 BENTON RD.
 PADUCAH, KY 42002-1760
 Page 1

ArchWeigh Belt Scale Installation and Operation

Wiring Diagram

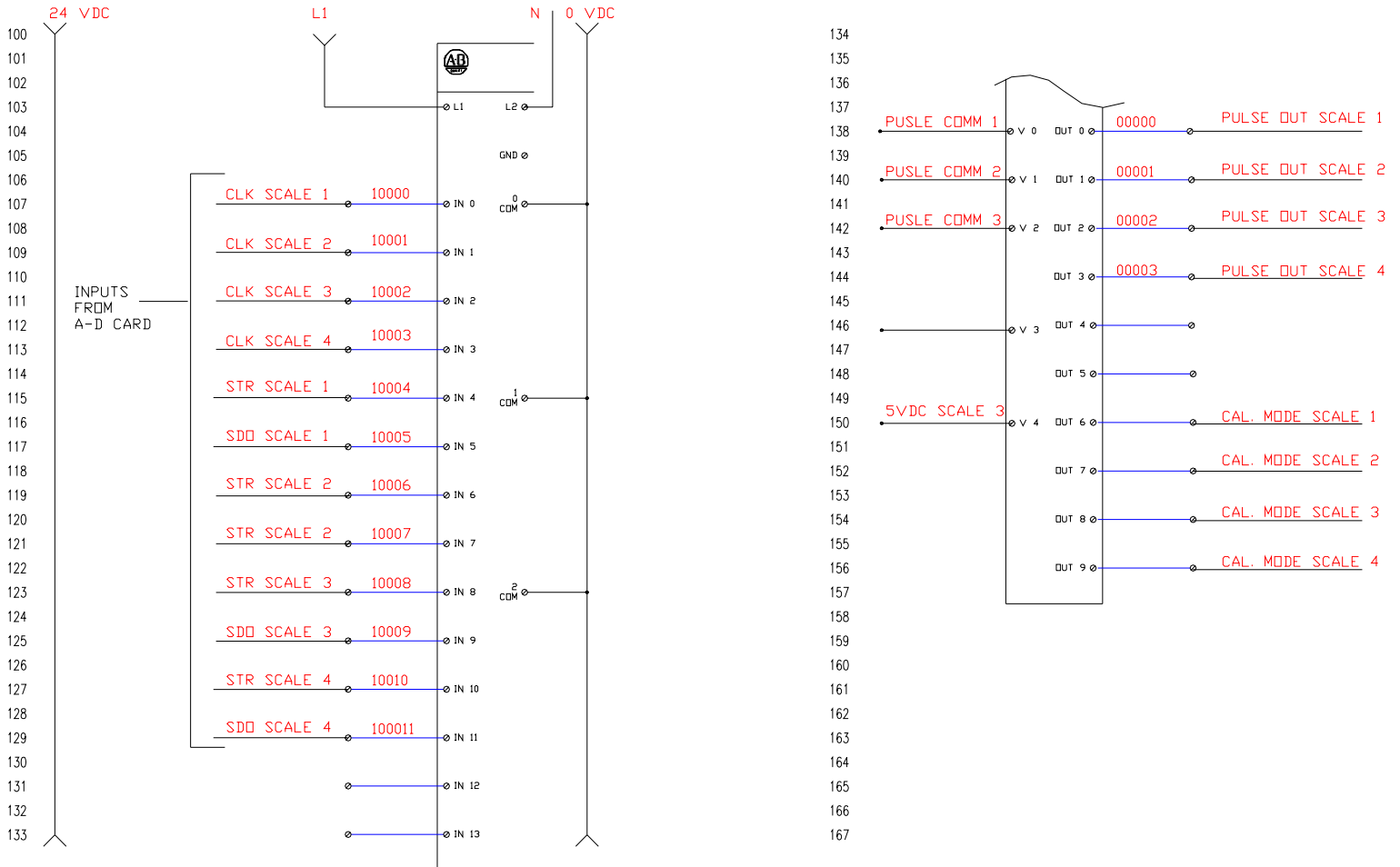

ArchWeigh Belt Scale Installation and Operation

Analog Output

100
101
102
103
104
105
106
107
108
109
110
111
112
113
114
115
116
117
118
119
120
121
122
123
124
125
126
127
128
129
130
131
132
133

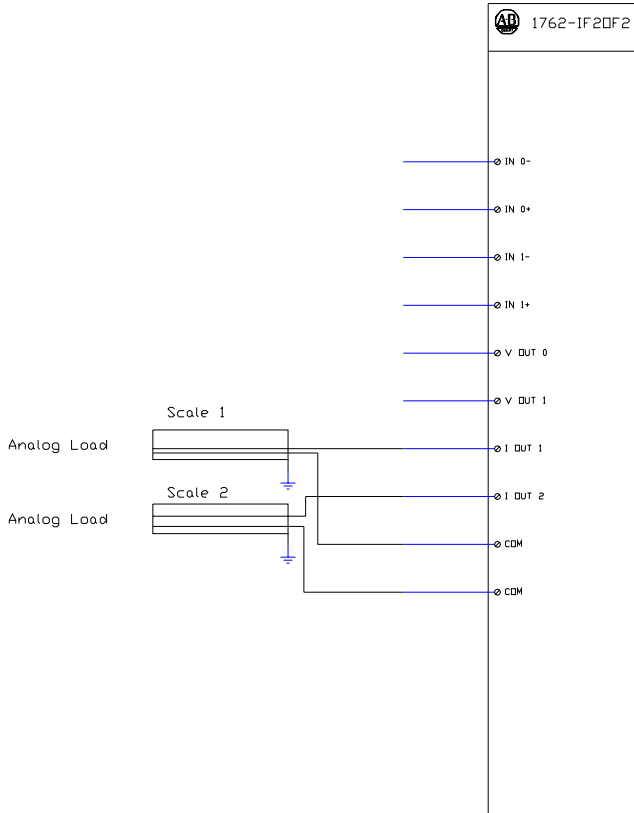

134
135
136
137
138
139
140
141
142
143
144
145
146
147
148
149
150
151
152
153
154
155
156
157
158
159
160
161
162
163
164
165
166
167

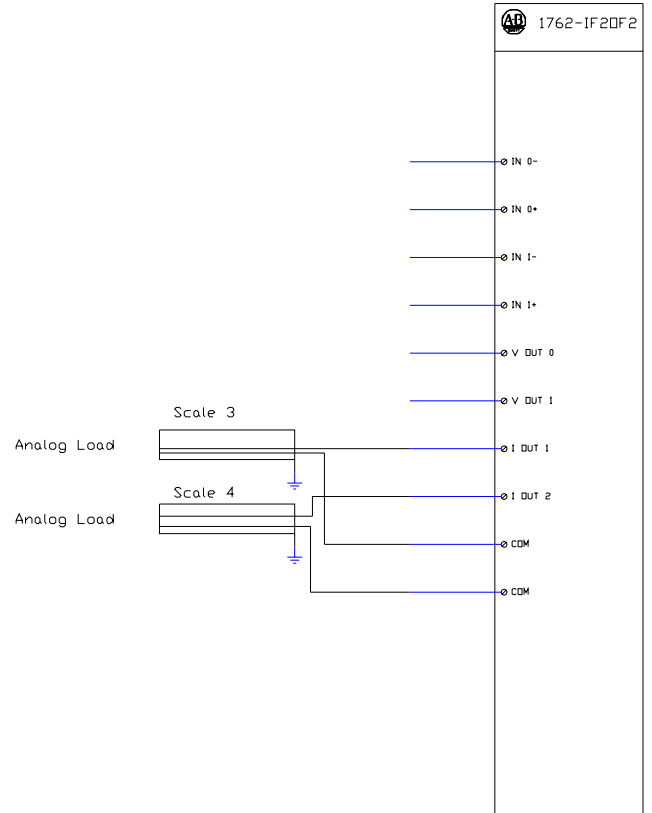

ArchWeigh Belt Scale Installation and Operation

Tare Flowchart

Archweigh HP/SC Tare

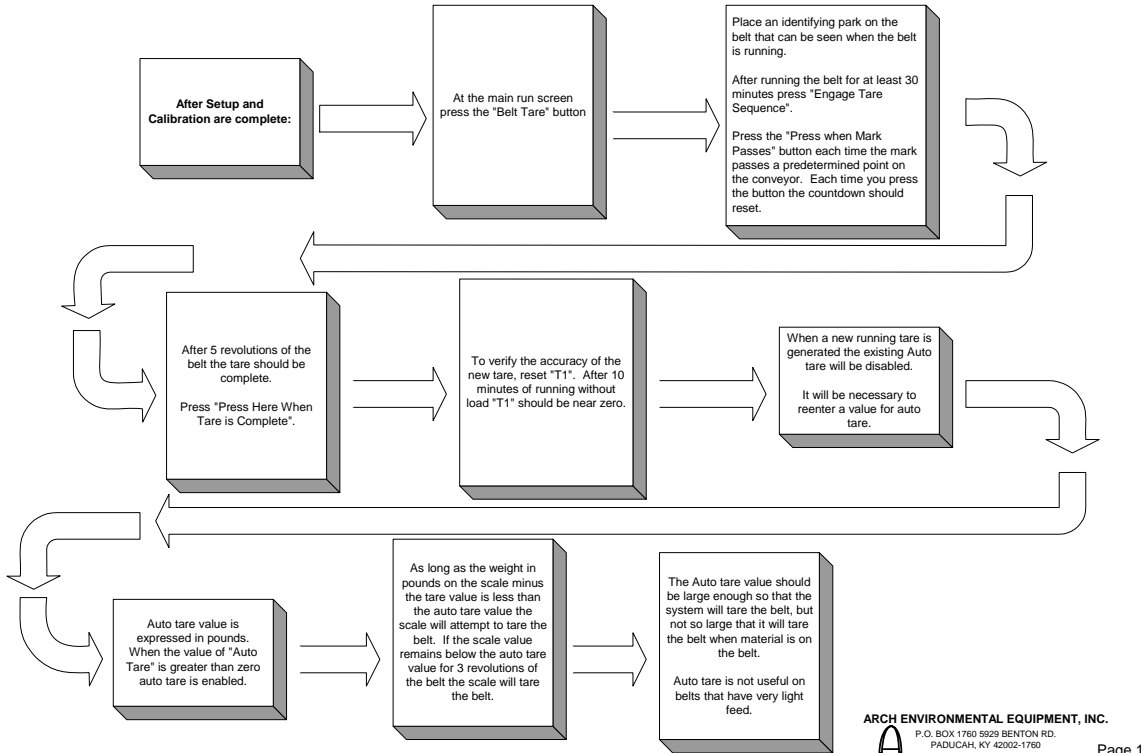

ARCH ENVIRONMENTAL EQUIPMENT, INC.
P.O. BOX 1760 5629 BENTON RD.
PADUCAH, KY 42002-1760

ArchWeigh Belt Scale Installation and Operation

Calibrate Flowchart

Archweigh HP/SC Scale Calibration

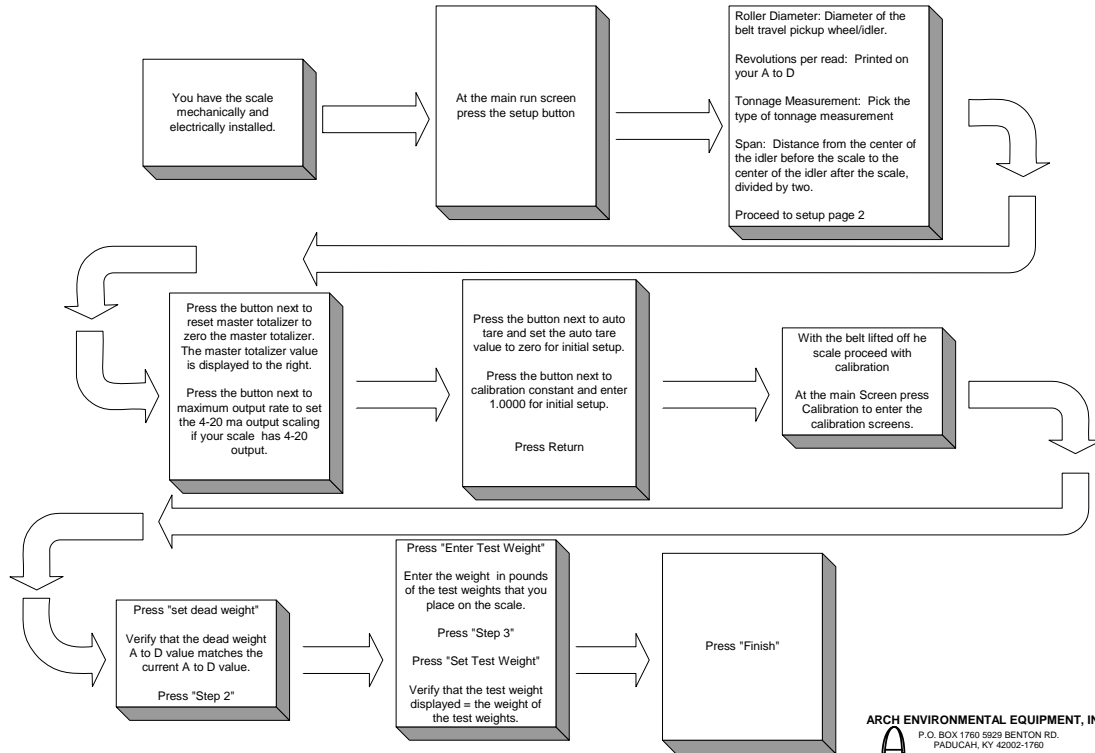

ARCH ENVIRONMENTAL EQUIPMENT, INC.
P.O. BOX 1760 5929 BENTON RD.
PADUCAH, KY 42002-1760

ArchWeigh Belt Scale Installation and Operation

Calibration Constant

Archweigh Belt Scale Calibration Constant

A calibration constant is determined by comparing Scale readings against known weights by performing a material test. It is preferable to use at least three samples in a material test so that repeatability can also be determined. The preferred method of material test is to collect material that has crossed the belt scale in a container that can be statically weighed. In this example trucks are used to collect the samples.

	Truck Scale Reading	- Archweigh Reading	= Deviation	Deviation	+ Truck Scale Reading	= Error			
Truck 1	56.4	- 56.2	= 0.200000	0.200000	56.4	= 0.003546			
Truck 2	56	- 55.9	= 0.100000	0.100000	56	= 0.001786			
Truck 3	52	- 51.85	= 0.150000	0.150000	52	= 0.002885			
Truck 4	58.9	- 58.88	= 0.020000	0.020000	58.9	= 0.00034			
Truck 5	51	- 50.9	= 0.100000	0.100000	51	= 0.001961			
Total	274.3	- 273.73			51	= 0.010517	no of samples	total Accuracy	total Accuracy
	+total before cal constant	+old cal constant		(If there is no old cal constant enter 1)	5	= 0.002103354	5	0.002103354	50
	new Cal Constant	total before cal constant							

Divide the total of the Archweigh Reading by the old cal constant. Divide the total of the truck scale reading by the result of the above calculation. The result is the new cal constant.